

OPERATING AND SERVICE MANUAL

MODEL 1781B
DELAY GENERATOR

CERTIFICATION

The Hewlett-Packard Company certifies that this instrument was thoroughly tested and inspected and found to meet its published specifications when it was shipped from the factory. The Hewlett-Packard Company further certifies that its calibration measurements are traceable to the U.S. National Bureau of Standards to the extent allowed by the Bureau's calibration facility.

WARRANTY AND ASSISTANCE

All Hewlett-Packard products are warranted against defects in materials and workmanship. This warranty applies for one year from the date of delivery, or, in the case of certain major components listed in the operating manual, for the specified period. We will repair or replace products which prove to be defective during the warranty period. No other warranty is expressed or implied. We are not liable for consequential damages.

Service contracts or customer assistance agreements are available for Hewlett-Packard products that require maintenance and repair on-site.

For any assistance contact your nearest Hewlett-Packard Sales and Service Office. Addresses are provided at the back of this manual.



OPERATING AND SERVICE MANUAL

**MODEL 1781B
DELAY GENERATOR**

SERIALS PREFIXED: 415-

**(For Other Serial Prefix Instruments
See Section I and Appendix I)**

**Copyright HEWLETT-PACKARD COMPANY 1963
1501 PAGE MILL ROAD, PALO ALTO, CALIFORNIA, U.S.A.**

Model 1781B
Delay Generator
Serials Prefixed: 415
Stock No. 1781B-902

TABLE OF CONTENTS

Section	Page	Section	Page
I GENERAL INFORMATION	1-1	4-27. Schmitt Trigger	4-4
1-1. Instrument Description and Uses	1-1	4-30. Tunnel Diode	4-5
1-4. Manual Identification and Changes.	1-1		
II INSTALLATION	2-1	V MAINTENANCE	5-1
2-1. Incoming Inspection	2-1	5-1. Introduction	5-1
2-4. Installation	2-1	5-3. Test Equipment	5-1
2-6. Repackaging for Shipment	2-1	5-5. Performance Checks	5-1
		5-8. Troubleshooting	5-1
III OPERATING INSTRUCTIONS	3-1	5-10. System Troubleshooting	5-1
3-1. Introduction	3-1	5-12. Sectional Troubleshooting.	5-1
3-3. Preparation for Use	3-2	5-14. Location of Parts	5-1
3-6. Operating Controls	3-2	5-16. Adjustments	5-1
3-8. Sweep Start Controls	3-2	5-18. Preset Adjust	5-6
3-14. Delay Controls	3-2	5-19. Trigger Sensitivity and Symmetry	5-6
3-21. Operating Considerations	3-3	5-20. Sweep Length Adjust	5-7
3-28. Operating Procedures	3-3	5-21. Sweep Calibration	5-7
		5-22. Delay Length-Delaying Sweep Adjust	5-8
IV PRINCIPLES OF OPERATION	4-1	5-23. Condensed Adjustment Procedure	5-9
4-1. Overall Functional Description	4-1	5-25. Repair and Replacement	5-10
4-3. Delaying Sweep Generator	4-1	5-26. Replacing Components	5-10
4-5. Amplifier and Trigger Generator	4-1	5-28. Adjustments After Replacement	5-10
4-9. Sweep Generator	4-2		
4-17. Sweep Selection	4-3	VI REPLACEABLE PARTS	6-1
4-22. Delayed Trigger Generator	4-4	6-1. Introduction	6-1
		6-4. Ordering Information	6-1

APPENDIX I I-1

LIST OF ILLUSTRATIONS

Number	Title	Page	Number	Title	Page
1-1.	Model 1781B Delay Generator	1-0	5-1.	Functional Block Diagram	5-1
1-2.	Waveforms Illustrating Sweep Combinations Using Model 1781B	1-2	5-2.	Location of Test Points	5-6
			5-3.	Location of Adjustments	5-7
3-1.	Front Panel Controls	3-2	5-4.	Trigger Adjustment Waveforms	5-8
3-2.	Delaying Sweep	3-4	5-5.	Location of Parts Mounted on Switch Assemblies A3 and A4	5-8
3-3.	Main Sweep, Delayed and Triggered	3-5	5-6.	Location of Parts on Sweep Time Switch, Right View	5-13
3-4.	Main Sweep, Delayed and Armed	3-6	5-7.	Location of Parts on Sweep Time Switch, Left View	5-13
3-5.	Mixed Sweep	3-7	5-8.	Location of Parts on Circuit Board	5-14
3-6.	Single Sweep	3-8	5-9.	Sweep Generator Schematic	5-15
			5-10.	Delayed Trigger Generator Schematic	5-16
4-1.	Overall Block Diagram	4-1	5-11.	Delaying Sweep Time Switch Schematic	5-17
4-2.	Delaying Sweep Generator	4-2	5-12.	Sweep Selector and Delay Function Switches Schematic	5-18
4-3.	Delayed Trigger Generator	4-4			
4-4.	Simplified Schmitt Trigger and Waveform	4-5			
4-5.	Tunnel Diode Operation	4-5			

LIST OF TABLES

Number	Title	Page	Number	Title	Page
1-1.	Model 1781B Specifications (with Model 175A Oscilloscope)	1-1	5-8.	Delay Trigger Generator Troubleshooting	5-5
			5-9.	Sweep Calibration	5-8
5-1.	Recommended Test Equipment	5-0	5-10.	Model 1781B Condensed Adjustment Procedure	5-9
5-2.	Trigger Sensitivity Check	5-0	5-11.	Adjustments Required Following Tube, Transistor, or Diode Replacement	5-11
5-3.	Delaying Sweep Accuracy Check	5-2	5-12.	Calibration and Component Replacement Record	5-12
5-4.	Delaying Sweep Linearity Check	5-3			
5-5.	System Troubleshooting	5-4	6-1.	Reference Designation Index	6-2
5-6.	Delaying Sweep Trigger Circuits Troubleshooting	5-4	6-2.	Replaceable Parts	6-7
5-7.	Delaying Sweep Generator Troubleshooting	5-5	6-3.	Code List of Manufacturers	6-10

APPENDIX I

MANUAL CHANGES

This appendix contains information on changes required to adapt this manual to an instrument with a serial prefix listed in the table below. Check for your instrument serial prefix and make numbered changes indicated. Note that these changes adapt the manual to cover a particular instrument as manufactured and therefore will not apply to an instrument subsequently modified in the field. Consult your Sales/Service Office for information on recommended field modifications. Refer back to Section I for information on errata in this manual and on any other instrument serial prefix not covered in this appendix.

Instrument Serial	Make Numbered Change (#)
412-	1, 2
320-00526 to 00975	1, 3
320-00176 to 00525	1, 2
309-	1 thru 4
305-	1 thru 3, 5

CHANGE 1

Page 5-15, Figure 5-9,

Disconnect R49 from anode side of CR6. Reconnect R49 between cathode side of CR6 and "-100V FROM H." Show R49 located on etched circuit board A1.

Page 5-17, Figure 5-11,

C37: Change value to 0.47 μ f.
 C38: Change value to 0.047 μ f.
 C39: Change value to 5600 PF.
 C40: Change value to 560 PF.
 C41: Change value to 56 PF.
 R75: Delete and remove connection.
 R87: Change value to 1 M ohm.

Tables 6-1 and 6-2,

C37: Change to μ Stock No. 0160-0015; C: fxd, paper, 0.47 μ f, 10%, 200VDCW; Mfr 56289; Mfr Part No. 109P47492.
 C38: Change to μ Stock No. 0170-0060; C: fxd, my, 0.047 μ f, 10%, 400VDCW; Mfr 84411; Mfr Part No. Type 663 UW.
 C39: Change to μ Stock No. 0140-0170; C: fxd, mica, 5600 PF, 5%, 300VDCW; Mfr 04062; Mfr Part No. DM20F562J.
 C40: Change to μ Stock No. 0140-0044; C: fxd, mica, 560PF, 10% NPO, 500VDCW; Mfr 28480; Mfr Part No. 0140-0044.
 C41: Change to μ Stock No. 0140-0014; C: fxd, mica, 56PF 10%, 500VDCW; Mfr. 00853; Mfr Part No. Type DR1456B10.

R75: Delete.

R87: Change to μ Part No. 0687-1051; R: fxd, comp, 1 M ohm, 10%, 1/2W; Mfr 01121; Mfr Part No. EB 1051.

CHANGE 2

Page 5-16, Figure 5-10,

R62: Change value to 36K ohms.

Tables 6-1 and 6-2,

R62: Change to μ Stock No. 0686-3635; R: fxd, comp, 36K ohms, 5%, 1/2W; Mfr 01121; Mfr Part No. EB 3635.

CHANGE 3

Page 5-16, Figure 5-10,

R63: Change value to 5K ohms.

Tables 6-1 and 6-2,

A8: Change to μ Stock No. 0757-0092; R: var, comp, 3 sect, 5K-5K-25K ohms, 30% 1/4W; Mfr 28480; Mfr Part No. 0757-0092.

CHANGE 4

Page 5-17, Figure 5-11,

Q3: May be either type 2N2048 (selected) or type 2N1373. Type 2N1373 is preferred replacement on 309- instrument serial prefix.

Add CR15, breakdown diode, on A2 circuit board. Connect anode to Q3 collector and cathode to Q3 base.

Tables 6-1 and 6-2,

Add CR15: μ Stock No. 1902-0056; Semiconductor; diode, breakdown; Mfr 28480; Mfr Part No. 1902-0056.

Q3: Change to μ Stock No. 1850-0070; Transistor: germanium, PNP 2N1373; Mfr 01295; Mfr Part No. 2N1373.

CHANGE 5

Page 5-15, Figure 5-9,

V12: Delete.

Page 5-17, Figure 5-11,

Q3: May be either a selected type, μ Stock No. 1850-0062 or a standard type 2N1370 (preferred replacement).

Tables 6-1 and 6-2,

Q3: Change to μ Stock No. 1850-0065; Transistor: PNP, 2N1370; Mfr 01295; Mfr Part No. 2N1370. (Preferred Replacement).

V12: Delete.

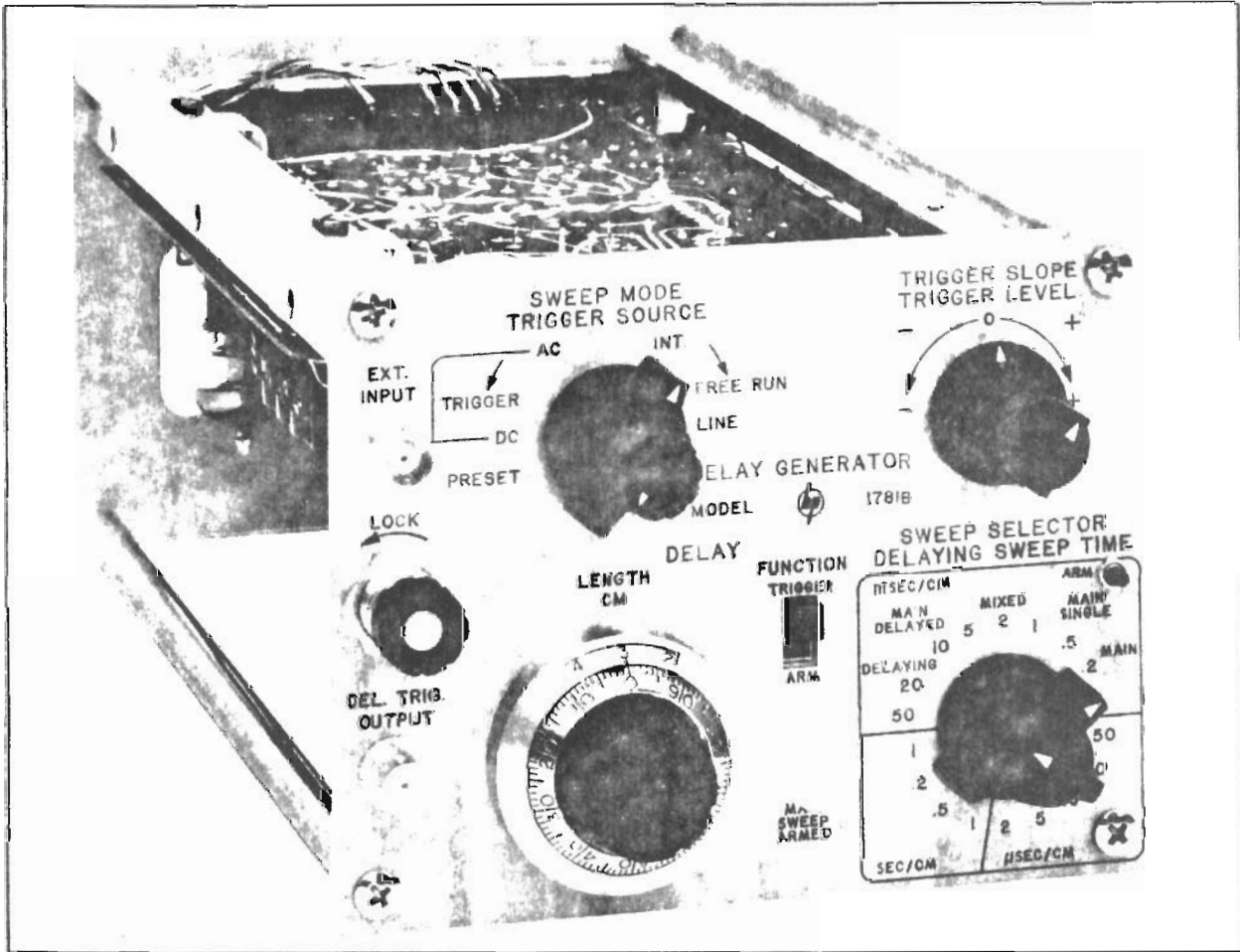

Figure 1-1. Model 1781B Delay Generator

SECTION I

GENERAL INFORMATION

1-1. INSTRUMENT DESCRIPTION AND USES.

1-2. The Hewlett-Packard Company Model 1781B Delay Generator plug-in (shown in figure 1-1) provides the \oplus Model 175A Oscilloscope with delayed sweep capability. With this plug-in any portion of a repetitive oscilloscope display can be selected and expanded for detailed viewing. Accurate measurements can be made to determine the delay time between a reference signal and a point of interest on a complex signal or pulse train and also to find the exact time interval between consecutive pulses in a pulse train or pulse burst. Transients at a step rise or fall of a signal can be observed and analyzed and time jitter between the reference signal and the observed signal can also be easily measured. Complete instrument specifications are given in table 1-1.

1-3. The Model 1781B generates a linear sweep which is used as a delaying sweep for the crt display. This delaying sweep can be combined with the oscilloscope main sweep in various modes. The length of the delaying sweep is variable and this is used to determine delay time, indicate the start of the delayed main sweep of the oscilloscope, and to provide a

mixed sweep mode. The mixed sweep feature makes it possible to view simultaneously the character of a whole pulse train and also "peel off" and expand individual pulses at the end of the train for detailed viewing. Figure 1-2 illustrates four types of sweeps possible by using the Model 1781B.

1-4. MANUAL IDENTIFICATION AND CHANGES.

1-5. This manual applies directly to Model 1781B instruments with a serial prefix of 415- (see manual title page). Hewlett-Packard Company uses a two-section eight-digit serial number to identify instruments, and the first three digits (i.e. those before the dash, as XXX-00000) are a serial prefix which is used to match printed material to instruments. For instruments with a serial prefix of 305- 309-, 320-, or 412- refer to Appendix I for difference data to adapt this manual. Other instruments are covered either by difference data in a change sheet (supplied with this manual) or by a separate Operating and Service Manual. Any errors in this manual when it was printed are called Errata and these corrections appear only in the change sheet included. To obtain correct information for any instrument, always specify the model number and serial prefix.

Table 1-1. Model 1781B Specifications (with \oplus Model 175A Oscilloscope)

<p>DELAY TIME: 0.5 μsec to 10 sec. Delay Time is the product of the DELAYING SWEEP TIME setting in sec/cm, and the DELAY LENGTH setting in cm.</p> <p>DELAYING SWEEP: 2 μsec/cm to 1 sec/cm. 18 calibrated ranges in 1, 2, 5, 10 sequence.</p> <p>DELAY LENGTH: (The physical location, in cm from the beginning of the trace, to the point at which the main sweep is triggered) 0 to 10 cm.</p> <p>DELAY ACCURACY: $\pm 1\%$ on 2 μsec/cm to 0.1 second/cm ranges; $\pm 3\%$ on 0.2, 0.5, 1 second/cm ranges. $\pm 0.2\%$ linearity.</p> <p>JITTER: $\pm 0.002\%$ of maximum delay on each range (1 part in 50,000).</p> <p>DELAY FUNCTIONS: (a) Trigger main sweep or (b) Arm main sweep.</p> <p>TRIGGERING: Internal, ac-coupled (2 mm or more vertical deflection); power line; or External, ac- or dc-coupled (1/2 volt p-p or more).</p> <p>TRIGGERING POINT: Controls allow selection of level and slope. Trigger level of external sync signal adjustable -5 to +5 volts.</p> <p>SWEEP SELECTOR: (a) Main Sweep, (b) Delaying Sweep - Brightened segment of trace indicates time relationship between delaying signal and main sweep display, (c) Main Delayed Sweep, (d) Mixed Sweep, (e) Single Sweep of main sweep.</p> <p>DELAYED TRIGGER OUTPUT: Approximately 10 volts positive.</p> <p>POWER: Supplied by Model 175A Oscilloscope.</p> <p>WEIGHT: Net 4-1/2 lb. Shipping 7 lb.</p>

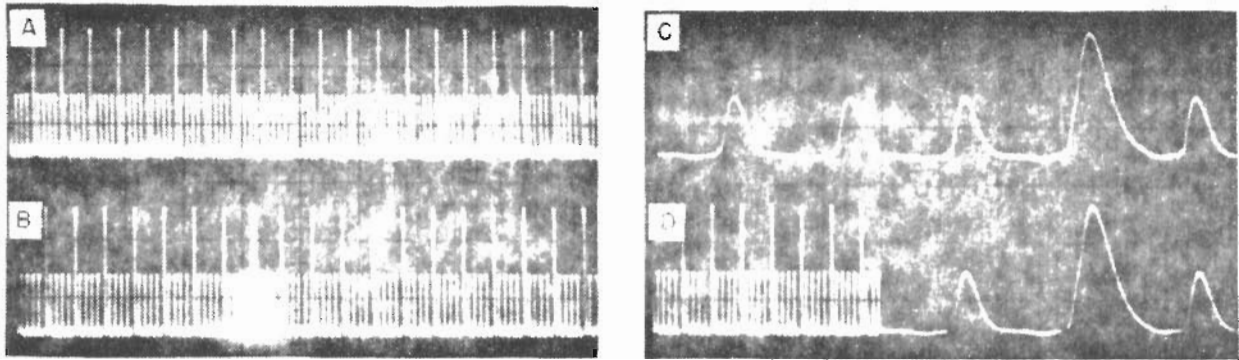

Figure 1-2. Waveforms illustrating sweep combinations using Model 1781B. (a) Main Sweep (using only Model 175A main sweep); (b) Delaying Sweep (section covered by delayed main sweep is intensified); (c) Main Delayed Sweep (intensified portion of B is expanded to entire horizontal 10 cm); and (d) Mixed Sweep (trace initially driven by slower Model 1781B delaying sweep and then by faster main sweep).

SECTION II INSTALLATION

2-1. INCOMING INSPECTION.

2-2. **MECHANICAL CHECK.** When the Model 1781B is received, inspect the instrument for any physical damage which occurred in shipping. Visually check inside the plug-in for loose or damaged components. If damage is found, file a claim with the responsible carrier or insurance company and refer to the warranty page of this manual. Paragraph 2-6 provides some suggestions for repackaging an instrument for shipment.

2-3. **PERFORMANCE CHECK.** The Model 1781B can be checked for electrical performance within the specifications of table 1-1 by following the procedures of paragraph 5-5. These procedures do not require any internal connections or adjustments. If the instrument fails to operate as specified, refer to the warranty page of this manual.

Note

To obtain the specified accuracy of the Model 1781B, operate it in an oscilloscope in which the +110 volt and -100 volt power supply voltages are within 0.4% of their nominal values.

2-4. INSTALLATION.

2-5. The Model 1781B is a plug-in unit for \odot Model 175A Oscilloscope. To install the Model 1781B, slide it into the lower left compartment of the oscilloscope directly below the crt. Lock the unit in place to insure good electrical and mechanical connection. All necessary operating power for the Model 1781B is supplied by the oscilloscope.

2-6. REPACKAGING FOR SHIPMENT.

2-7. Following is a guide for repackaging an instrument for shipment. If you have any questions, contact your authorized Hewlett-Packard representative.

a. If possible, use the original container designed for the instrument.

b. Wrap the instrument in heavy paper or plastic before placing it in the shipping container.

c. Use plenty of packing material around all sides of the instrument and protect panel faces with cardboard strips.

d. Use a heavy cardboard carton or wooden box to house the instrument and use heavy tape or metal band to seal the container.

e. Mark the packing box with "Fragile", "Delicate Instrument", or etc, as appropriate.

Note

If the instrument is to be shipped to Hewlett-Packard for service or repair, attach to the instrument a tag identifying the owner and indicating the service or repair to be accomplished. In any correspondence, identify the instrument by model number, serial number, and serial number prefix.

SECTION III OPERATING INSTRUCTIONS

3-1. INTRODUCTION.

3-2. The Model 1781B is a plug-in unit for use with the \odot Model 175A Oscilloscope. The unit generates a linear delaying sweep which is used to sweep the trace or delay the presentation of the main sweep for a selected time interval after an input trigger. At the end of the delay period, the Model 1781B produces a trigger pulse which can either trigger or arm the main sweep, depending upon the delay function selected. After the trigger, the main sweep can be used to take over the display, depending on settings of Model 1781B and oscilloscope controls. The trigger is also available at the front panel for external use. The sweep or

combination of sweeps to appear on the crt is determined by one of five sweep selections: 1) DELAYING in which delaying sweep drives the trace across the crt and the delayed main sweep appears as an intensified segment of the delaying sweep; 2) MAIN DELAYED, in which the delayed main sweep drives the trace across the crt; 3) MIXED, in which the delaying sweep drives the trace across the crt for approximately the delay period and the main sweep completes the trace; 4) MAIN SINGLE, in which the main sweep occurs only once with no delay when triggered, and must be re-armed before another trigger is effective; and 5) MAIN in which the main sweep operates normally and drives the trace across the crt with no delay.

3-3. PREPARATION FOR USE.

3-4. For **ted** accuracy of the Model 1781B operating in any Model 175A Oscilloscope, make sure the +110 volt and -100 volt power supply voltages in the oscilloscope are within 0.4% of their nominal values. Refer to the Model 175A manual for the adjustment procedure.

3-5. To permit best use of mixed-sweep operation, the trace produced by the main sweep must be slightly longer in time than the trace produced by the delaying sweep. Check the relative sweep lengths as described in paragraph 5-7.

3-6. OPERATING CONTROLS.

3-7. Front-panel controls and their functions are shown in figure 3-1. The paragraphs below provide detailed explanations for the control and connector functions indicated in the figure.

3-8. SWEEP START CONTROLS.

3-9. Four front-panel controls affect the start of the delaying sweep. They include the TRIGGER SOURCE switch, TRIGGER LEVEL control, TRIGGER SLOPE switch, and SWEEP MODE control.

3-10. TRIGGER SOURCE selects the source of the sweep trigger: the power line (LINE), the signal applied to the vertical amplifier of the oscilloscope (INT), or an external signal applied to the EXT. INPUT connector (AC or DC).

3-11. TRIGGER LEVEL selects the voltage level on the trigger signal at which the sweep starts. The control provides continuous adjustment of the trigger level

from about -5 volts to about +5 volts on external signals and over a range equivalent to about 6 centimeters of vertical deflection on internal trigger signals.

3-12. TRIGGER SLOPE determines whether the delaying sweep starts on the positive-slope or negative-slope portion of the trigger signal.

3-13. SWEEP MODE determines whether the delaying sweep requires a trigger or free runs. The control is continuously adjustable with a switched PRESET position at its counterclockwise extreme. This PRESET position is internally set for optimum trigger operation. For very high frequency trigger signals, it may be desirable to use a free-running mode of trigger operation. Maximum stability will be obtained with slight re-adjustment of SWEEP MODE and TRIGGER LEVEL controls.

3-14. DELAY CONTROLS.

3-15. The FUNCTION, DELAYING SWEEP TIME, LENGTH, and SWEEP SELECTOR controls all affect the delay or the way the delay appears on the crt.

3-16. FUNCTION determines whether the Model 1781B triggers or arms the main sweep at the end of the delay period. With FUNCTION set to TRIGGER, the Model 1781B starts the main sweep immediately after the delay period. After completing its cycle, the main sweep is ready for another starting trigger from the Model 1781B.

3-17. With the FUNCTION set to ARM, the Model 1781B arms but does not start the main sweep at the end of delay period. The main sweep then requires a trigger as selected by the TRIGGER SOURCE switch of the oscilloscope. After one cycle, the main sweep remains disabled until rearmed by Model 1781B.

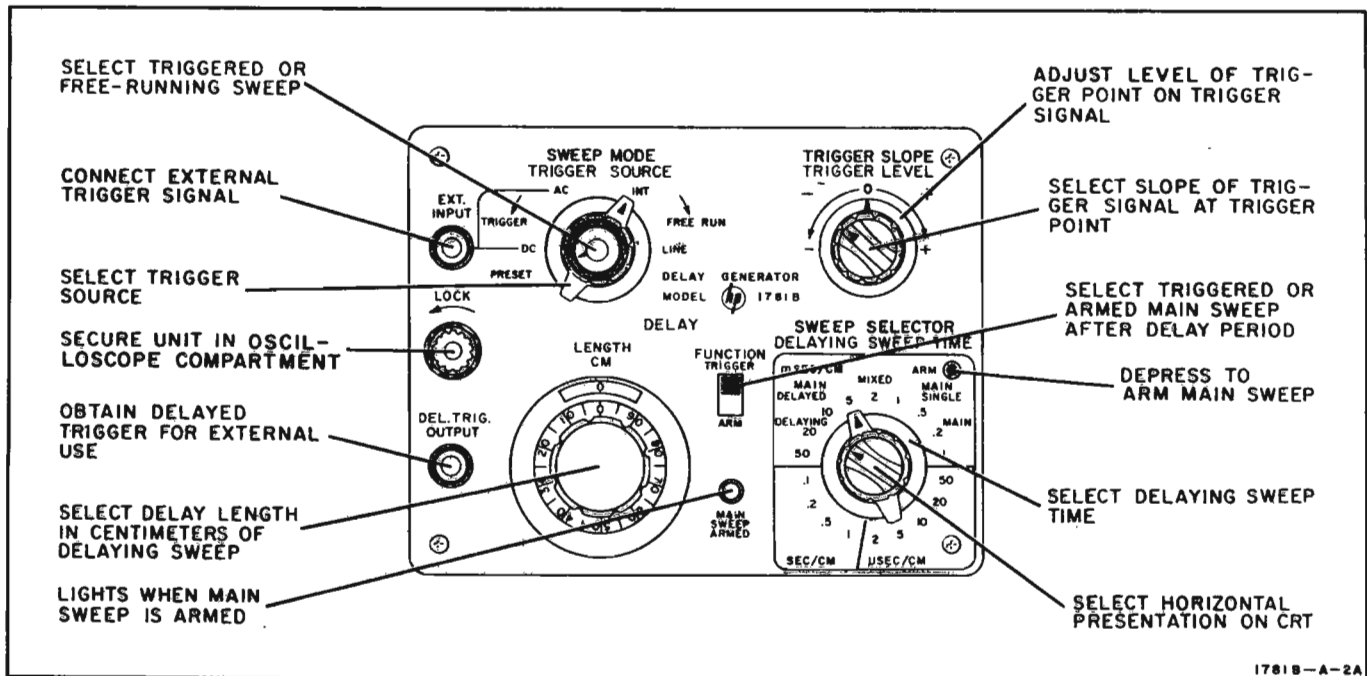

Figure 3-1. Front Panel Controls

3-18. **DELAYING SWEEP TIME** determines the sweep time of the delaying sweep whether or not the delaying sweep appears on the crt. This sweep is the reference for delay measurements.

3-19. **LENGTH** determines delay length measured in centimeters along the delaying sweep. Thus the delay period is the product of the **LENGTH** and **DELAYING SWEEP TIME** settings.

3-20. **SWEEP SELECTOR** determines the horizontal presentation on the crt. There are five options explained as follows:

a. **DELAYING.** The delaying sweep drives the trace across the crt. The main sweep is triggered (or armed) at the end of the delay period, and the time interval of the main sweep is indicated by a brightened segment on the crt display.

b. **MAIN DELAYED.** The main sweep drives the trace across the crt after the delay period. The display on the crt is the expansion of the brightened segment of the delaying sweep display described in a.

c. **MIXED.** The delaying sweep drives the trace for the delay period, and then triggers the main sweep. The trace is then driven by the main sweep which is farther along in its cycle. To drive the trace during any part of the display, the main sweep used must be fast enough to pass the delaying sweep before the delaying sweep drives the trace off the right-hand side of the crt screen. (There is a display on the crt even though the main sweep is slower than the delaying sweep, but it is not usable.) Since in **MIXED** sweep there is some delay beyond that indicated by the **LENGTH** control, total delay should be read from the crt.

d. **MAIN SINGLE.** After the **ARM** switch is depressed and released, the main sweep, when triggered, drives the trace across the crt with no delay.

e. **MAIN.** The oscilloscope operates normally; the main sweep drives the trace across the crt; there is no delay.

3-21. OPERATING CONSIDERATIONS.

3-22. **DELAYED TRIGGER OUTPUT.** The delayed trigger available at the front-panel **DEL. TRIG. OUTPUT** connector coincides with the trigger signal applied internally to the main sweep generator of the oscilloscope. The delay indicated by the **DELAY LENGTH** control and **DELAYING SWEEP TIME** switch is the time interval between the start of the delaying sweep and the delayed trigger regardless of whether the main sweep is triggered or armed. Thus, the delayed trigger can be used as a delayed trigger for external circuits, as a timing pulse, etc., regardless of the delay function selected.

3-23. **FUNCTION.** The **FUNCTION** switch determines whether the main sweep is triggered or armed at the end of the delay period. The **TRIGGER** function is intended for actual delay measurements. Since the

main sweep starts at the end of the delay period, the **LENGTH** dial indicates the delay between the start of the delaying sweep and main sweep. Additional delay can be measured along the delayed main sweep, and high resolution is possible when main-sweep speed is high compared to delaying-sweep speed. However, the oscilloscope delays the vertical signal 0.2 μ sec before applying it to the crt (refer to the oscilloscope manual); this delay should be accounted for when using the fastest delaying and main sweeps.

3-24. The **ARM** function effectively eliminates jitter between the trigger for the delaying sweep and the trigger for the main sweep because the main sweep is armed only, not started, at the end of the delay period. An additional trigger starts the main sweep, and this trigger need not be synchronized with the delaying sweep. For example, if there is pulse-to-pulse jitter in a train of pulses, it is possible to trigger the delaying sweep with one pulse and trigger the main sweep with the first pulse to occur after the delay period. The signal immediately following the main-sweep trigger pulse can then be observed jitter-free even though it is not synchronized with the delaying-sweep trigger. In the **ARM** function, the **LENGTH** dial indicates minimum possible delay. Actual delay must be read from the crt.

3-25. **SWEEP SELECTION.** There are three combinations of delaying and delayed main sweeps. **DELAYING** sweep permits selection of delay and main sweep time prior to selection of the delayed presentation, because the time relationship of the delayed main sweep to the delaying sweep is indicated by a brightened segment on the crt display. The brightened segment then can be positioned with the **LENGTH** control and lengthened or shortened with the oscilloscope **SWEEP TIME** switch to cover just that part of the display to be examined in detail.

3-26. **MAIN DELAYED** provides the delayed presentation. The display is the brightened segment of the delaying sweep expanded to the full 10 cm of the crt horizontal axis.

3-27. **MIXED** permits both slow and fast sweeps to appear along the same trace. The delaying sweep is the slow sweep and starts at the left side of the crt. The main sweep is the fast sweep and takes over from the delaying sweep at a point determined by the **LENGTH** setting and difference in sweep speeds. Thus, for example, a train of pulses can be observed on the left side of the crt on the slow part of the trace while a single pulse can be examined in detail on the right side of the crt on the fast part of the trace.

3-28. OPERATING PROCEDURES.

3-29. Figures 3-2 through 3-6 give procedures for different operating modes with the Model 1781B. These instructions are supplemented by operating instructions given in the oscilloscope manual. Procedures are given step-by-step, and each step is numbered. Controls to which a step refers are keyed to the same number as the step.

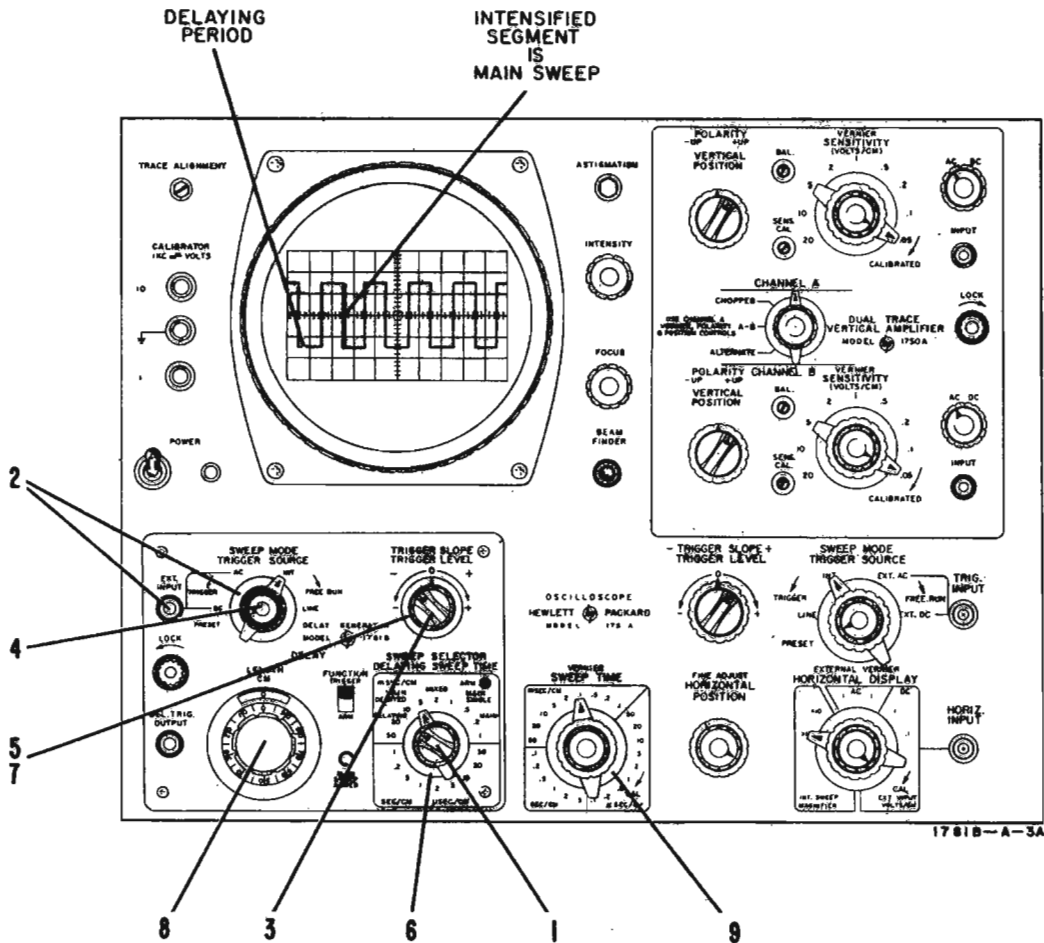

1. Set SWEEP SELECTOR to DELAYING.
2. Set TRIGGER SOURCE as desired. If external trigger is used, connect trigger signal to EXT. INPUT.
3. Set TRIGGER SLOPE for triggering on positive or negative slope of trigger signal as desired.
4. Set SWEEP MODE to PRESET.
5. Set TRIGGER LEVEL to 0.
6. Set DELAYING SWEEP SOURCE TIME to desired sweep time.
7. Reset TRIGGER LEVEL to start trace at desired signal level. It may be necessary to switch SWEEP MODE from PRESET and select a better setting for the particular signal being viewed.
8. Adjust LENGTH for desired delay period.
9. Adjust length of intensified segment with oscilloscope SWEEP TIME.

Figure 3-2. Delaying Sweep

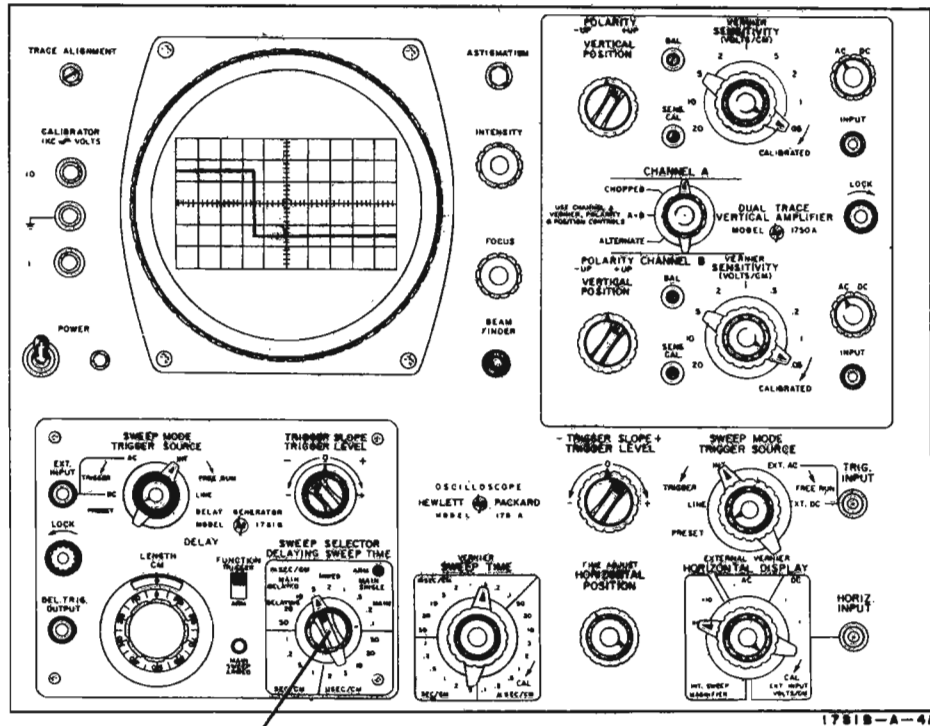

2

1. Perform steps 1 thru 9, figure 3-2.
2. Set SWEEP SELECTOR to MAIN DELAYED. The presentation is the intensified segment expanded. The expansion ratio is (DELAYING SWEEP TIME) : (SWEEP TIME).

Figure 3-3. Main Sweep, Delayed and Triggered

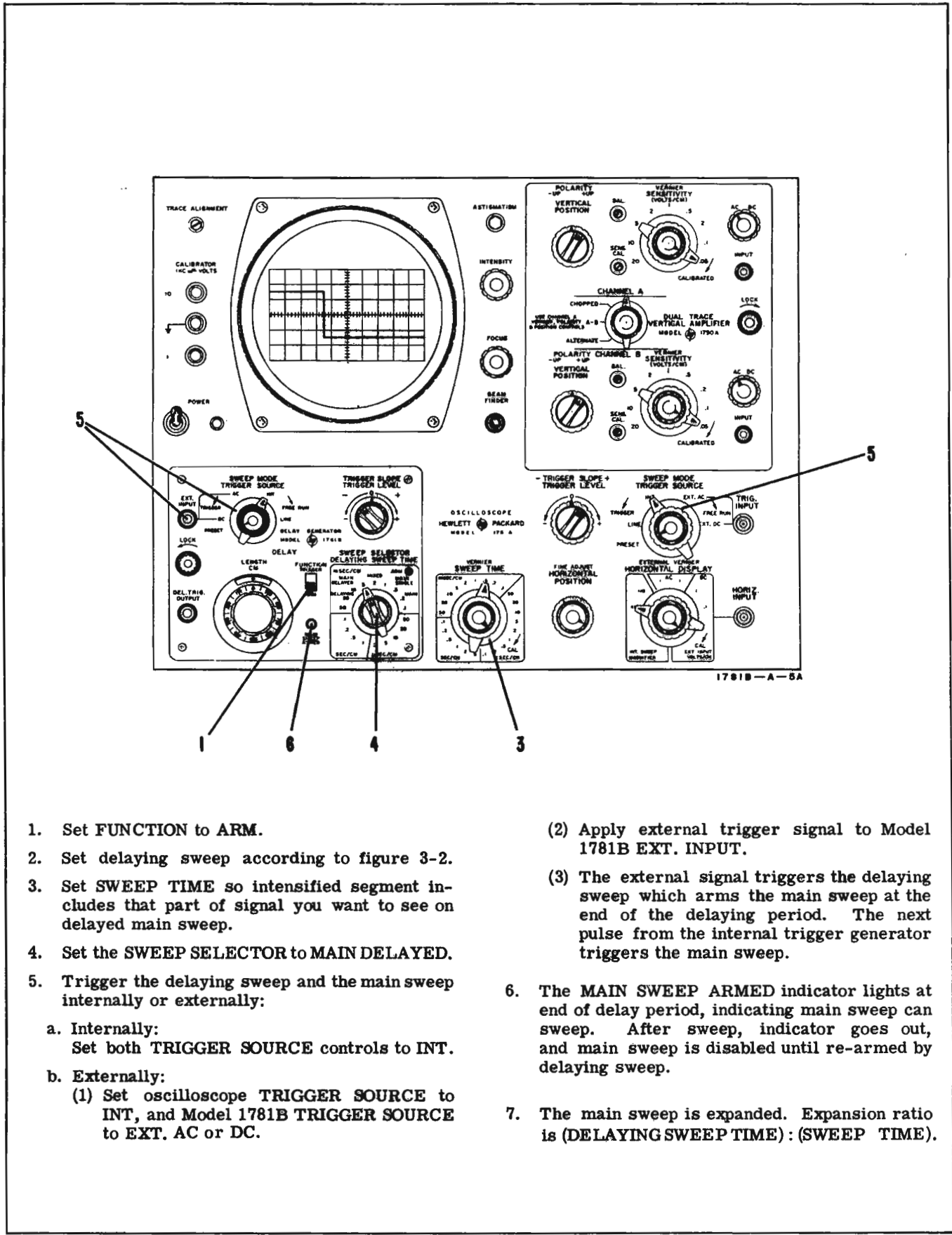

1. Set **FUNCTION** to **ARM**.
2. Set delaying sweep according to figure 3-2.
3. Set **SWEEP TIME** so intensified segment includes that part of signal you want to see on delayed main sweep.
4. Set the **SWEEP SELECTOR** to **MAIN DELAYED**.
5. Trigger the delaying sweep and the main sweep internally or externally:
 - a. Internally:
Set both **TRIGGER SOURCE** controls to **INT**.
 - b. Externally:
 - (1) Set oscilloscope **TRIGGER SOURCE** to **INT**, and Model 1781B **TRIGGER SOURCE** to **EXT. AC** or **DC**.
 - (2) Apply external trigger signal to Model 1781B **EXT. INPUT**.
 - (3) The external signal triggers the delaying sweep which arms the main sweep at the end of the delaying period. The next pulse from the internal trigger generator triggers the main sweep.
6. The **MAIN SWEEP ARMED** indicator lights at end of delay period, indicating main sweep can sweep. After sweep, indicator goes out, and main sweep is disabled until re-armed by delaying sweep.
7. The main sweep is expanded. Expansion ratio is $(\text{DELAYING SWEEP TIME}) : (\text{SWEEP TIME})$.

Figure 3-4. Main Sweep, Delayed and Armed

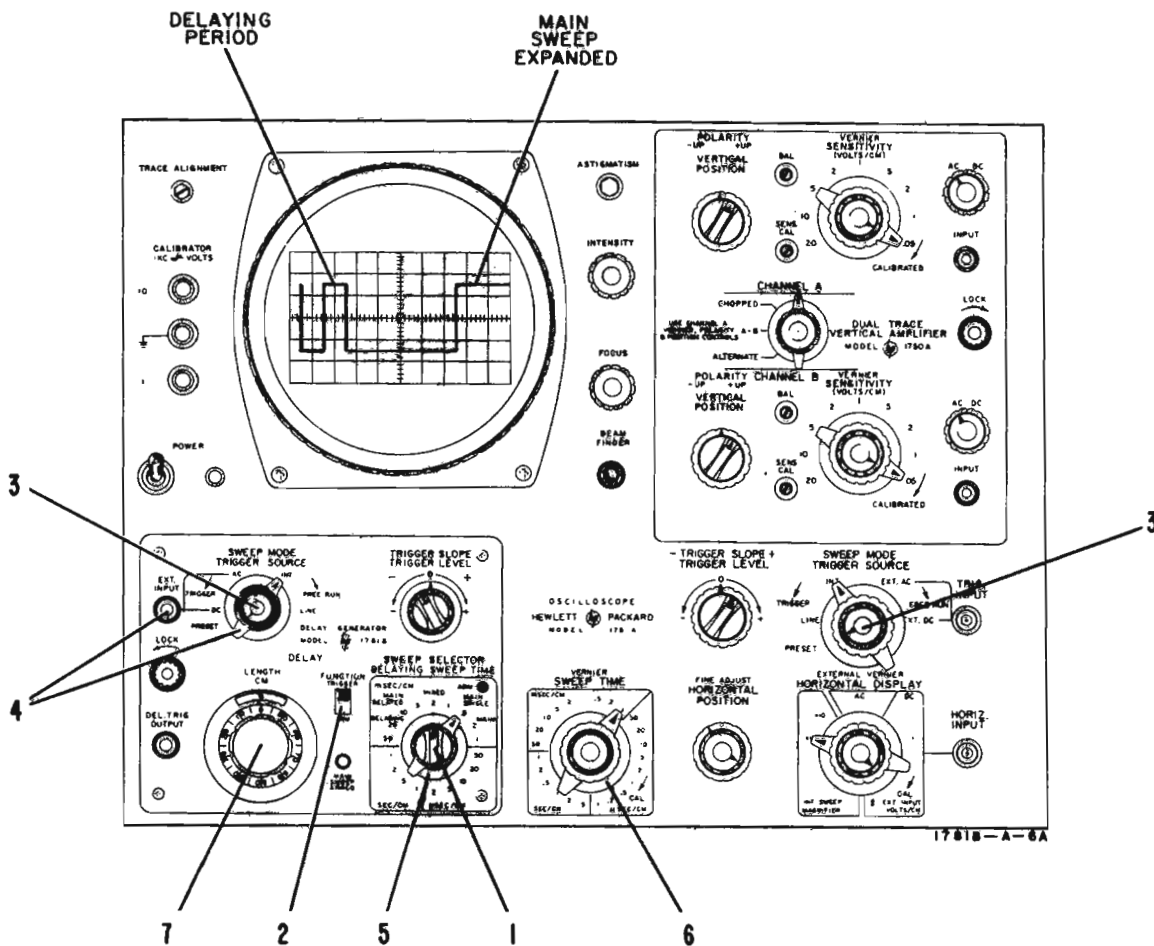

1. Set SWEEP SELECTOR to MIXED.
2. Set FUNCTION to TRIGGER.
3. Set SWEEP MODE on oscilloscope and Model 1781B to PRESET.
4. Trigger delaying sweep as desired. (If external triggering is used, connect trigger signal to EXT. INPUT.)
5. Set DELAYING SWEEP TIME to desired sweep time.
6. Set SWEEP TIME to desired sweep time (faster than delaying sweep).
7. Set LENGTH for desired delaying period. (Delay is not calibrated in mixed sweep operation.)

Figure 3-5. Mixed Sweep

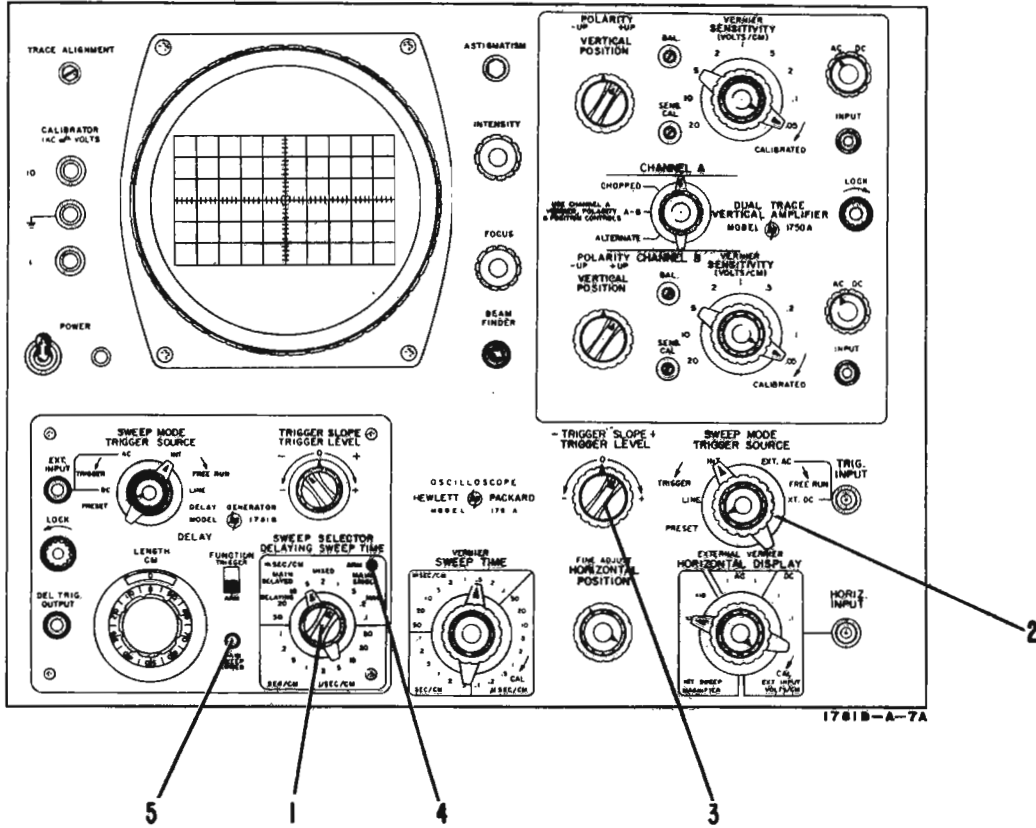

1. Set SWEEP SELECTOR to MAIN SINGLE.
2. Set oscilloscope TRIGGER SOURCE according to trigger signal used.
3. Set oscilloscope TRIGGER SLOPE and TRIGGER LEVEL as desired.
4. To arm sweep, depress and release ARM switch.
5. MAIN SWEEP ARMED indicator on Model 1781B should light. A signal from the vertical channel triggers the circuit to produce a single sweep, and a single trace is displayed. At the end of the sweep the MAIN SWEEP ARMED indicator goes off. (This operation is useful in the observation and photography of transient signals which are not repetitive.)
6. Repeat step 4 (above) to re-arm sweep after each trigger.

Figure 3-6. Single Sweep

SECTION IV PRINCIPLES OF OPERATION

4-1. OVERALL FUNCTIONAL DESCRIPTION.

4-2. The Model 1781B provides the Model 175A Oscilloscope with delayed sweep operation. The unit inserts a known amount of delay, which can be selected at the front panel, between a reference trigger and the start of the main sweep generated by the oscilloscope. The Model 1781B itself consists of a delaying sweep generator and a delayed-trigger generator as shown in figure 4-1. The sweep generator produces a linear voltage ramp, the delaying sweep, which is applied to the delayed-trigger generator. The delayed-trigger generator generates a trigger at the end of the delay period selected at the front panel and delivers the trigger to the main sweep generator of the oscilloscope, which then provides the delayed sweep.

4-3. DELAYING SWEEP GENERATOR.

4-4. A block diagram of the delaying sweep generator is shown in figure 4-2. In addition to the actual sweep generating circuits (V2, 3, 5, 7, and 11), the delaying sweep generator contains amplifying and shaping circuits (V1, CR1, and Q1) and gating circuits (V6). The amplifying and shaping circuits provide adequate triggering of the sweep circuits, and the gating circuits provide unblanking to the crt.

4-5. AMPLIFIER AND TRIGGER GENERATOR.

4-6. The input or reference trigger is applied to one grid of tube V1, a differential amplifier, and a dc signal from the TRIGGER LEVEL control is applied to the other grid. The output of the amplifier is a

single-ended signal which is proportional to the difference between the trigger and dc signals. As shown in the figure, the TRIGGER SLOPE switch reverses the trigger and dc signals, when switched from one polarity position to the other. The switch thereby determines the phase between the trigger signal and the output of the amplifier. With the switch set to +, the output amplifier V1 is 180° out of phase with the trigger signal; with the switch set to -, the output of the amplifier is in phase with the trigger signal.

4-7. The output of amplifier V1 must be negative-going and must cross the switching level of tunnel diode CR1 to start a sweep. Since the output of the amplifier is proportional to the difference between the trigger signal and the dc value selected by the TRIGGER LEVEL control the point on the trigger signal at which the diode switches depends upon the setting of the control. Thus the TRIGGER LEVEL control permits selection of the voltage level which the trigger signal must cross to start a sweep.

4-8. The signal from amplifier V1 is applied to trigger generator CR1, a tunnel diode. (See paragraph 4-30 for a discussion of tunnel diodes.) Provided the signal crosses both switching limits, trigger generator CR1 switches back and forth between its two stable states, generating positive-going and negative-going voltage steps at its output. These steps are differentiated by C5 to form short pulses, and applied through amplifier Q1 as triggers to gate generator V3/V5A. Only the negative triggers actuate the Schmitt trigger, and CR2 (not shown) reduces the amplitude of the positive triggers.

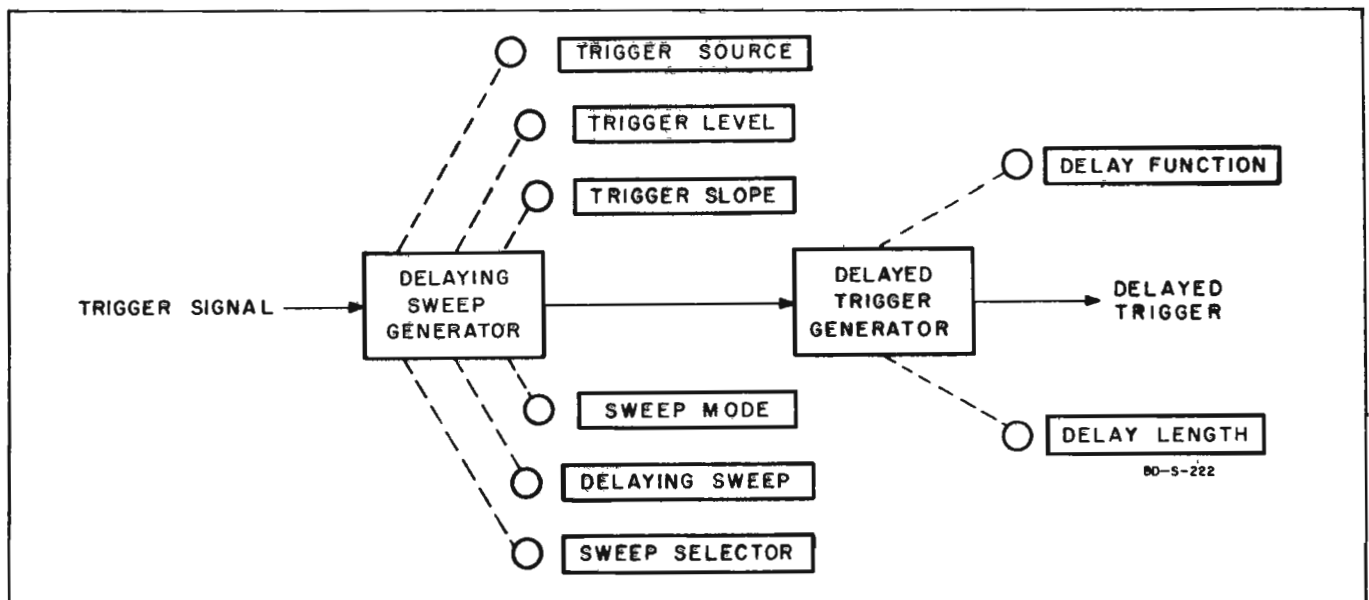

Figure 4-1. Overall Block Diagram

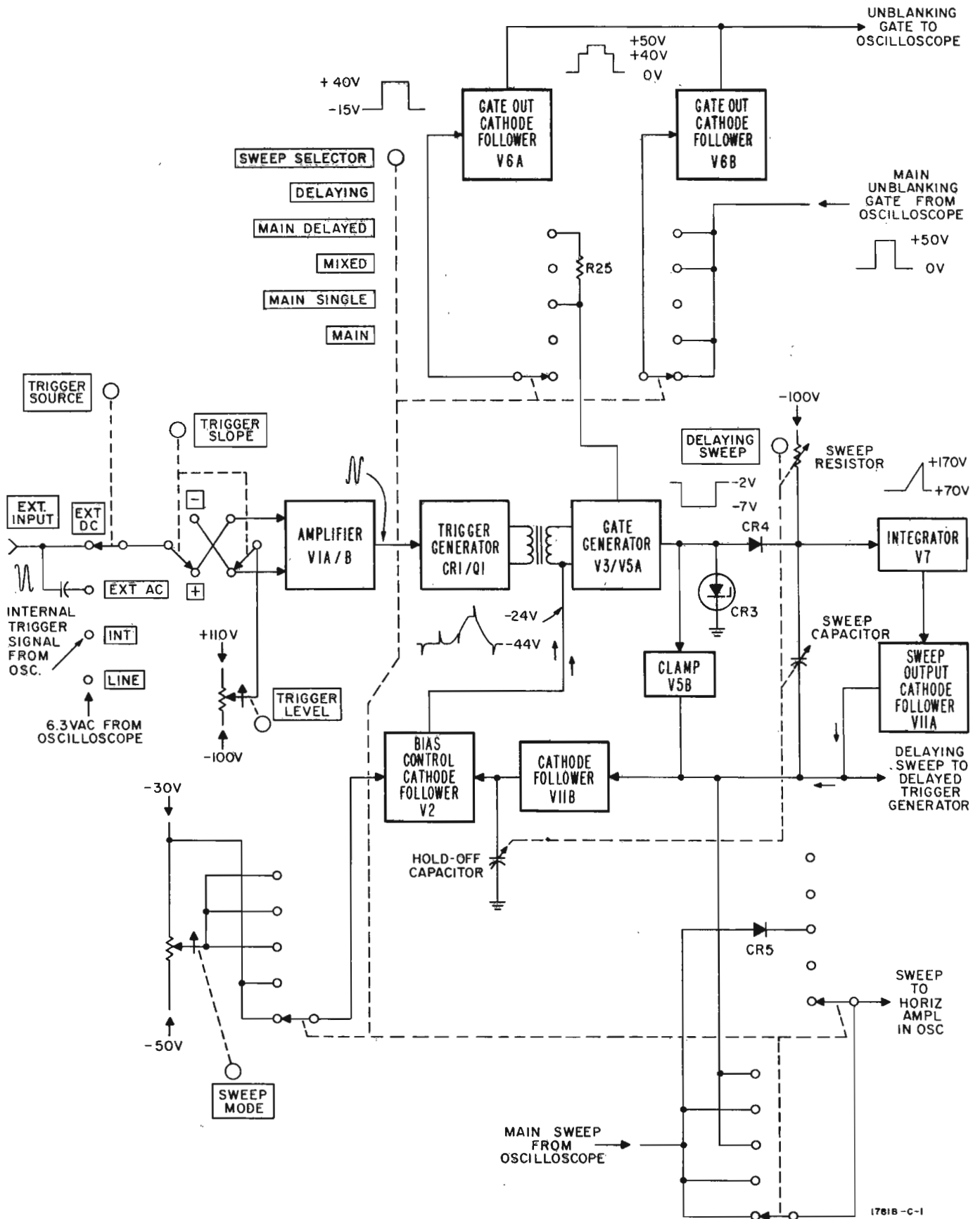

Figure 4-2. Delaying Sweep Generator

4-9. SWEEP GENERATOR.

4-10. Gate generator V3/V5A is a Schmitt trigger with wide hysteresis limits. Between sweeps, the A section of bias control cathode follower V2 holds the bias at the input of the gate generator close to the lower hysteresis limit. Thus a positive trigger from trigger amplifier Q1 has no effect, but a negative trigger drives the input to the gate generator below the lower hysteresis limit and causes the gate generator to switch.

4-11. When it switches, gate generator V3/V5A provides a positive and negative gate. The positive gate is applied to the high voltage power supply in the oscilloscope to unblank the crt beam. The negative gate is applied to diode CR4 to start the sweep. Prior to the gate, CR4 had been forward biased and had been holding the input to integrator V7 at about -2 volts. The negative gate reverse-biases the diode and frees the integrator input.

4-12. Once freed, the input to the integrator starts going more negative, for it is connected to -100 volts through the sweep resistor. Integrator V7 amplifies and inverts its input and produces a large, positive-going output which is applied back to the input through sweep output cathode follower V11A and the sweep capacitor. As a result, the input to the integrator changes by about 0.5 volt during sweep time. The voltage across the sweep resistor therefore changes about 0.5% during sweep time, and the current through the resistor changes by the same percent. Since the current through the sweep resistor is the charging current for the sweep capacitor, the voltage across the sweep capacitor changes quite linearly with time, and the sweep signal is a nearly linear voltage ramp. The DELAYING SWEEP TIME switch changes the value of the sweep resistor or capacitor to change sweep time. Emitter follower Q3 applies a constant voltage to the fixed sweep resistors. Sweep output is applied to the delayed-trigger generator and to the DELAYING and MIXED positions of the SWEEP SELECTOR switch.

4-13. An attenuated sweep signal is applied to the input of gate generator V3/V5A through cathode follower V11B and the B section of bias control cathode follower V2. This signal drives the input of the gate generator to the upper hysteresis limit and causes the gate generator to switch back to its pre-sweep state. The gate generator then ends the gates, removing its unblanking signal from the crt and forward biasing CR4. Diode CR4 then returns the input to integrator V7 to its pre-sweep level, resetting the sweep.

4-14. During sweep time, cathode follower V11B charges a hold-off capacitor. After the sweep ends, this capacitor lets the input to gate generator V3/V5A down slowly enough to prevent that circuit from being triggered again until the remaining sweep circuits have recovered. The DELAYING SWEEP TIME switch changes the size of the hold-off capacitor with sweep time.

4-15. Clamp V5B insures that each sweep starts from the same voltage level, about -50 volts.

4-16. The SWEEP MODE control determines the pre-sweep bias at the input to gate generator V3/V5A by setting the bias on the A section of bias control cathode follower V2. With the control set to PRESET or in the TRIGGER portion of its adjustable range, the gate generator bias cannot drop below its lower hysteresis limit unless trigger amplifier Q1 provides a trigger. However, with the SWEEP MODE control set in the FREE RUN part of its range, the gate generator bias can drop below its lower hysteresis limit. Thus as the hold-off capacitor discharges, it lets the gate generator bias fall to the lower hysteresis limit, and another sweep starts automatically.

4-17. SWEEP SELECTION.

4-18. The SWEEP SELECTOR switch determines the way the delaying and main sweeps appear on the crt. With the switch set to MAIN, the delaying sweep generator is disabled by the fixed bias applied to gate generator V3/V5A, the main sweep from the oscilloscope is routed back to the horizontal amplifier of the oscilloscope, and the main unblanking gate from the oscilloscope is applied back to the oscilloscope through gate out cathode follower V6B.

4-19. With the SWEEP SELECTOR set to DELAYING, the delaying sweep generator operates normally, the delaying sweep is applied to the horizontal amplifier in the oscilloscope, and the oscilloscope main sweep is disconnected. The unblanking gates from the delaying sweep generator and the oscilloscope main sweep generator are mixed in the common cathode circuits of V6. The delaying sweep unblanking gate, which is of longer duration than the main unblanking gate is reduced by R25 to a lower amplitude than that of the main unblanking gate. As a result, the main unblanking gate appears as a pedestal on top of the delaying sweep unblanking gate (this waveform is shown in the upper right-hand corner of figure 5-9, Sweep Generator schematic). The pedestal brightens the trace on the crt during the time of the delayed main sweep.

4-20. With SWEEP SELECTOR set to MAIN DELAYED, the delaying sweep generator operates normally, but the delayed main sweep is applied to the horizontal amplifier in the oscilloscope. The main unblanking gate is applied to the oscilloscope, and the delaying sweep unblanking gate is disconnected.

4-21. With SWEEP SELECTOR set to MIXED, the delaying sweep is applied to the horizontal amplifier in the oscilloscope, and the delayed main sweep is applied to the anode of diode CR5. The cathode of CR5 is connected to the delaying sweep output. Therefore the delaying sweep signal is applied to the oscilloscope so long as the delaying sweep is more positive than the delayed main sweep. When the main sweep becomes the more positive signal, CR5 becomes forward biased, and the main sweep is applied both to the oscilloscope and to gate generator V3/V5A. Thus, the main sweep completes the trace on the crt and terminates the delaying sweep as well.

4-22. DELAYED TRIGGER GENERATOR.

4-23. DELAYED TRIGGER. The delayed trigger generator is shown in figure 5-10. A simplified block diagram is given in figure 4-3. In the absence of an input signal, pin 2 of V14 is at -50 volts, and that section of the dual triode is cut off. All current supplied by constant-current generator Q5/V15A flows through the left section of V14. The voltage at the common cathodes of V14, and thus the cut-off bias of the right section, is set by LENGTH control. The delay period is the time required for the delaying sweep to rise from the quiescent level (-50 volts) to the level which will cause the right half of V14 to conduct. The left section is quickly cut off and the full current supplied by the constant current source flows through the right section. The sudden surge of current through tunnel diode CR10 switches the diode, producing a sharp negative voltage step which will become the delayed trigger. The retrace slope of the delaying sweep cuts off the right-section again, thus returning the circuit to the original condition.

4-24. The sharp negative step from CR10 is amplified and shaped by Q5 into a trigger pulse. The trigger pulse is applied to phase splitter V15B, which provides outputs of both positive and negative triggers. The positive trigger is applied to FUNCTION switch S5 and the DEL. TRIG. OUTPUT connector. The negative trigger is applied only to FUNCTION switch S5.

4-25. DELAY FUNCTION. The DELAY FUNCTION switch selects either the positive or negative pulse from phase splitter V15B and applies the pulse to bias control cathode follower V109A in the sweep generator

of the oscilloscope. In addition, FUNCTION determines the type of operation of the main sweep generator. With FUNCTION set to TRIGGER, the main sweep generator operates normally, and the negative pulse from phase splitter V15B starts the main sweep.

4-26. When set to ARM, the FUNCTION switch converts V109 in the oscilloscope sweep generator to a Schmitt trigger, thereby setting the main sweep generator for single-sweep operation. The positive pulse from phase splitter V15B sets the Schmitt trigger circuit of V109 to arm the main sweep generator, which then produces a sweep when triggered through the triggering circuits of the oscilloscope itself.

4-27. SCHMITT TRIGGER.

4-28. The Schmitt trigger circuit is a form of bi-stable multivibrator used where fast-rising signals are required. Figure 4-4 shows a simplified Schmitt circuit and input and output waveforms. If initially the input voltage is such that V1 is cut off, V2 conducts. As the input voltage becomes more positive, it will eventually reach a predetermined level (a) at which the circuit changes state; V1 conducts and V2 is cut off. If the input voltage then goes negative, the common cathode potential decreases and V2 grid goes positive. When the input reaches a second predetermined level (b), V2 conducts and the circuit switches back to its initial state. The output of the circuit is a voltage step, either positive or negative depending upon the slope of the input.

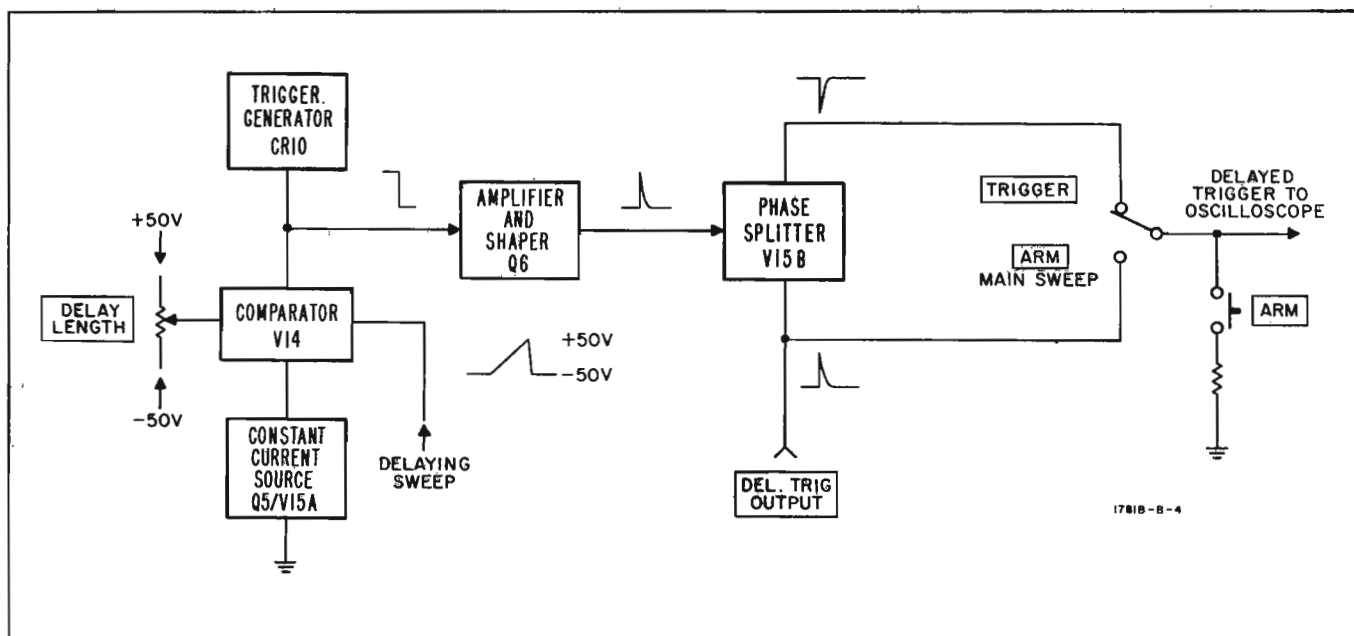

Figure 4-3. Delayed Trigger Generator

4-29. The input voltage levels at which a Schmitt trigger switches are the hysteresis limits. Note that the circuit does not switch unless the input crosses both limits.

4-30. TUNNEL DIODE.

4-31. Figure 4-5 shows a tunnel diode triggering circuit of the type used in the Model 1781B. Tunnel diode CR1 is part of the plate load of triode tube V1. CR1 is biased at point A on the E-I curve, and is stable at this point. If a positive pulse is fed to the grid of V1, the current through V1 (and hence tunnel diode current) will increase. As the current passes the high current knee of the curve at point B, the tunnel diode enters its negative resistance region. Diode current therefore begins to decrease. Tube V1 acts as a constant current source, however, and prevents current from decreasing; the current difference flows into C_x , the junction capacity. As a result, diode voltage switches rapidly to a higher voltage at point E. Then when the input pulse falls again to zero, diode voltage falls to point D, where it is again stable. When a negative reset pulse decreases diode current below point C, the diode switches back to the low voltage state, and returns to the original stable condition at point A when the input pulse falls to zero. The switching between high and low voltage state produces a square wave output with fast rise and fall times.

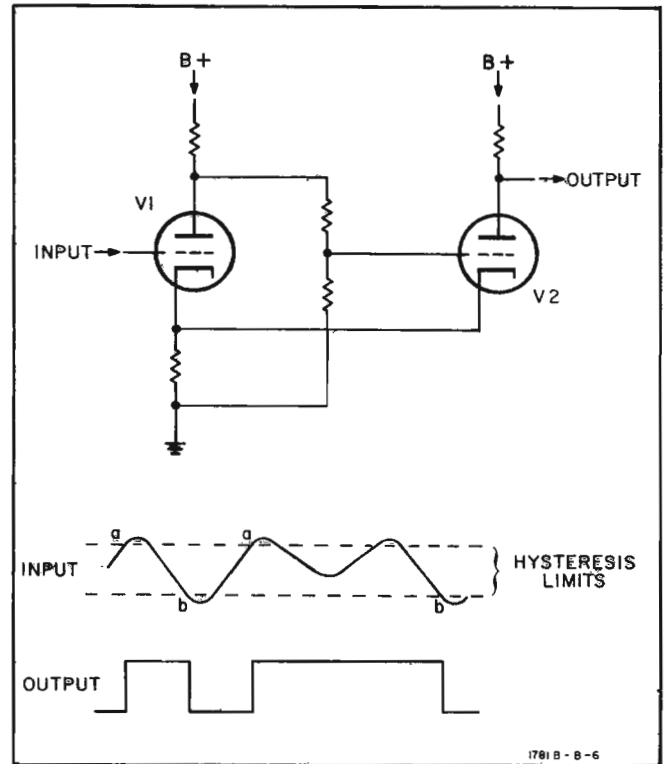

Figure 4-4. Simplified Schmitt Trigger and Waveform

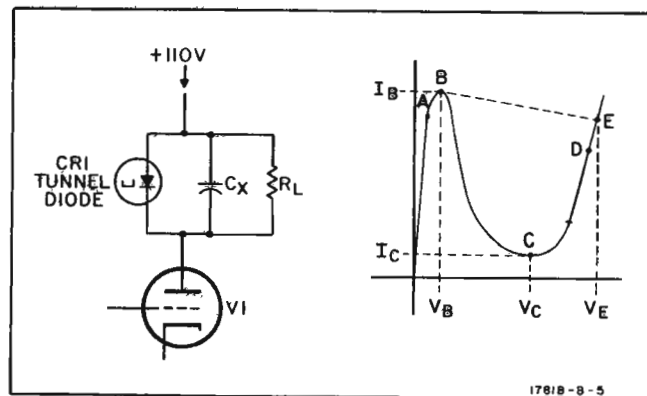
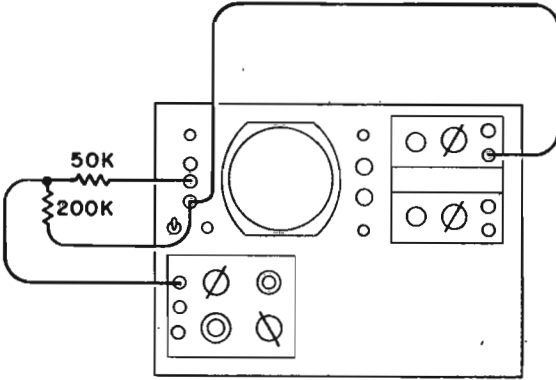

Figure 4-5. Tunnel Diode Operation

Table 5-1. Recommended Test Equipment

Instrument Type	Required Characteristics	Use	Recommended Instrument
Precision DC Voltmeter	Voltage Range: 100 to 110 volts Accuracy: 0.1%	Adjust low voltage power supply in oscilloscope	Ⓜ Model 3440A or John Fluke 801
Oscillator	Frequency: 600 kc Output: 10 volts into 600 ohms	Signal source for sweep length adjustment	Ⓜ Model 200CD
DC Voltmeter/ Ohmmeter	Voltage Range: 1 volt to 400 volts Accuracy: 3% Input Resistance: 100 megohms Resistance Range: 10 ohms to 10 megohms	Voltage and resistance measurements	Ⓜ Model 410B/C or Ⓜ Model 412A
Time Mark Generator	Marker Interval: 1 microsecond to 5 seconds Accuracy: 0.05%	Check delay time accuracy and linearity	Tektronix 180A
AC Voltage Calibrator	Approx. 400-cps sine wave output; calibrated for 200 mv peak-to-peak output and 30-50 mv rms output.	Adjust trigger sensitivity and symmetry	Ⓜ Model 738AR

Table 5-2. Trigger Sensitivity Check

<div style="display: flex; align-items: flex-start;"> <div style="flex: 1;">  <p style="text-align: center;">Ⓜ 175A OSCILLOSCOPE</p> </div> <div style="flex: 2; padding-left: 20px;"> <p>OSCILLOSCOPE:</p> <p>VERTICAL SENSITIVITY TO 5 VOLTS/CM</p> <p>VERNIER TO CALIBRATED</p> <p>SWEEP TIME TO 1 MSEC/CM</p> <p>MODEL 1781B:</p> <p>TRIGGER LEVEL TO 0</p> <p>TRIGGER SLOPE TO +</p> <p>SWEEP MODE TO PRESET</p> <p>TRIGGER SOURCE TO INT</p> <p style="text-align: right; font-size: small;">1781B - B - 1A</p> </div> </div>		
Step	Preliminary Action	Performance Standard
1	Connect 1 VOLT terminal of CALIBRATOR to vertical INPUT.	Sweep triggered without jitter
2	Connect a 5:1 voltage divider across the 1 VOLT CALIBRATOR terminal, and apply one fifth the CALIBRATOR output voltage to Model 1781B TRIGGER INPUT. Switch TRIGGER SOURCE to EXT. INPUT.	Sweep triggered without jitter

SECTION V MAINTENANCE

5-1. INTRODUCTION.

5-2. This section provides instructions for periodic maintenance checks and adjustments, troubleshooting, and repair on Model 1781B. If the instrument does not meet specifications (refer to table 1-1), perform the necessary circuit adjustment given under Calibration (paragraphs 5-16 through 5-24). If adjustment is not sufficient to bring the accuracy within specifications, a repair or replacement may be necessary; troubleshoot to determine the nature and location of the fault. A repaired circuit may require a recalibration and a performance check.

5-3. TEST EQUIPMENT.

5-4. Test equipment required for troubleshooting, performance check, and adjustment of the Model 1781B is listed in table 5-1. Equipment of equivalent characteristics may be substituted for those listed.

5-5. PERFORMANCE CHECKS.

5-6. Performance of the Model 1781B when plugged into a Model 175A Oscilloscope can be checked as follows:

- a. Trigger Sensitivity - see table 5-2.
- b. Delaying Sweep Accuracy - see table 5-3.
- c. Delaying Sweep Linearity - see table 5-4.
- d. Mixed Sweep Operation - see paragraph 5-7.

Note

The delay time accuracy of the Model 1781B depends on the +110 and -100 voltages supplied by the oscilloscope. These voltages should be adjusted to be within 0.4% of their nominal values before performance checks or adjustments are made. Refer to table 5-1 for recommended equipment and to the oscilloscope manual for adjustment procedure.

5-7. For proper mixed-sweep operation, check relative sweep lengths as follows:

- a. On Model 1781B, set SWEEP SELECTOR to MIXED, DELAY LENGTH to about 5 CM, DELAY FUNCTION to TRIGGER, and SWEEP MODE to FREE RUN.
- b. On oscilloscope, set SWEEP MODE to PRESET.
- c. Set DELAYING SWEEP TIME on Model 1781B to 20, 10, 5, 2 and 1 MSEC/CM and make SWEEP TIME setting on oscilloscope so main sweep in each case is 100 times faster than delaying sweep.

- d. Observe trace on crt for each combination of sweeps. Left half of trace should be brighter than right half. An increase of trace intensity at right end of the trace indicates incorrect relative sweep lengths. Refer to figure 3-5 for setting and adjustment, paragraph 4-21 for functional explanation, and oscilloscope manual for the oscilloscope sweep time adjustments.

5-8. TROUBLESHOOTING.

5-9. The procedure for troubleshooting the Model 1781B is divided into two categories: (1) overall or system troubleshooting and (2) sectional troubleshooting. For the purpose of system troubleshooting, the Model 1781B is considered to be a system; the oscilloscope is not included. The Model 1781B is divided into the three sections shown in figure 5-1. System troubleshooting procedures (see paragraph 5-10) isolate troubles to one of the sections, and sectional troubleshooting procedures (see paragraph 5-12) isolate troubles within the section.



Figure 5-1. Functional Block Diagram

5-10. SYSTEM TROUBLESHOOTING.

5-11. Before starting the system troubleshooting, visually check Model 1781B for such items as loose or broken parts, cold solder joints, etc. Following the visual inspection, proceed to the system troubleshooting procedure given in table 5-5. When a faulty section is located, check the section for obvious troubles. In many cases instrument failure is due to a defective electron tube. The instrument can then be returned to service by replacing the tube and checking the calibration of the particular circuit repaired. Refer to paragraph 5-28 for more information.

5-12. SECTIONAL TROUBLESHOOTING.

5-13. Tables 5-6, 5-7 and 5-8 provide procedures for sectional troubleshooting. The test points specified in the tables are located in figure 5-2 and are shown on the schematic diagrams, figures 5-9 and 5-10.

5-14. LOCATION OF PARTS.

5-15. Except for fixed resistors and capacitors, components on etched circuit assembly A1 are identified by silkscreening. All components on A1 and those mounted on switch assemblies are identified in pictures (figures 5-5 through 5-8) located just before the schematic diagrams in this manual section.

5-16. ADJUSTMENTS.

5-17. The procedures below give instructions for the complete calibration of the Model 1781B. Paragraph 5-23 provides a condensed adjustment procedure which may be useful after procedures of paragraphs 5-18 through 5-22 are familiar.

Note: The Model 1781B must be adjusted in a Model 175A Oscilloscope which is correctly calibrated horizontally, and has the +110 and -100 volt supplies adjusted to an accuracy of $\pm 0.4\%$ or better, preferably $.05\%$. The Model 1781B is then interchangeable in similarly-calibrated Model 175A's.

Table 5-3. Delaying Sweep Accuracy Check

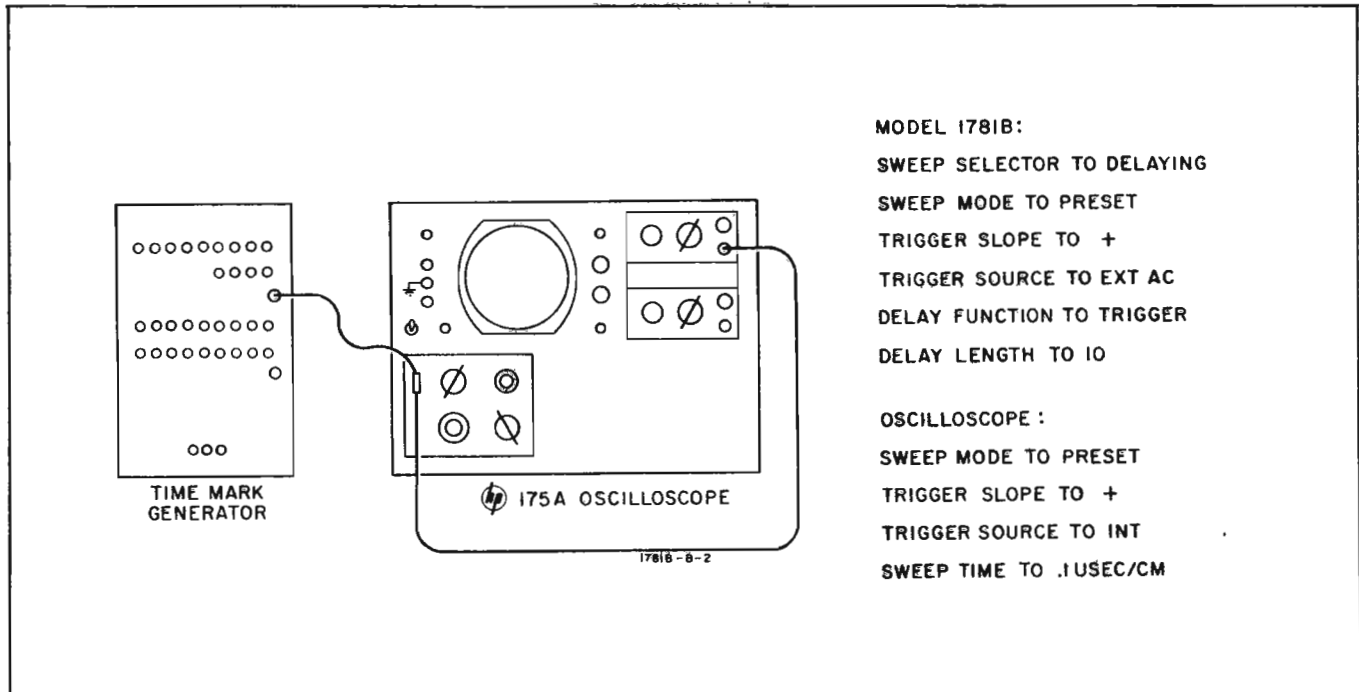

Step	Preliminary Action	Read Indication On	Performance Standard
1	Connect Time-Mark Generator (1 microsecond markers) to oscilloscope vertical INPUT. Set Model 1781B DELAYING SWEEP TIME to 2 μSEC/CM and adjust TRIGGER LEVEL controls for stable sweep. Adjust DELAY LENGTH to put brightened part of trace under third marker (approximately 1 cm). Set SWEEP SELECTOR to MAIN DELAYED and adjust DELAY LENGTH to put leading edge of marker at start of trace. Record DELAY LENGTH setting.	DELAY LENGTH dial	Difference between DELAY LENGTH readings must be 9 cm ± 10 minor divisions
2	Adjust DELAY LENGTH to put leading edge of 21st marker at start of trace (approximately 10 cm). Record DELAY LENGTH setting.		
3	Repeat for all ranges of DELAYING SWEEP TIME as listed in the following table.		

DELAYING SWEEP TIME Setting	175A Sweep Time	Time-Mark Generator	Check Markers	Performance Standards 9 cm ± Minor Divisions.
2 μSEC/CM	.2 μSEC/CM	1 μsec	3 21	10
5 μSEC/CM	.5 μSEC/CM	5 μsec	2 11	10
10 μSEC/CM	1 μSEC/CM	10 μsec	2 11	10
20 μSEC/CM	2 μSEC/CM	10 μsec	3 21	10
50 μSEC/CM	5 μSEC/CM	50 μsec	2 11	10
.1 MSEC/CM	10 μSEC/CM	100 μsec	2 11	10
.2 MSEC/CM	20 μSEC/CM	100 μsec	3 21	10
.5 MSEC/CM	50 μSEC/CM	500 μsec	2 11	10
1 MSEC/CM	.1 MSEC/CM	1 msec	2 11	10
2 MSEC/CM	.2 MSEC/CM	1 msec	3 21	10
5 MSEC/CM	.5 MSEC/CM	5 msec	2 11	10
10 MSEC/CM	1 MSEC/CM	10 msec	2 11	10
20 MSEC/CM	2 MSEC/CM	10 msec	3 21	10
50 MSEC/CM	5 MSEC/CM	50 msec	2 11	10
.1 SEC/CM	10 MSEC/CM	100 msec	2 11	10
.2 SEC/CM	20 MSEC/CM	100 msec	3 21	30
.5 SEC/CM	50 MSEC/CM	500 msec	2 11	30
1 SEC/CM	.1 SEC/CM	1 sec	2 11	30

Table 5-4. Delaying Sweep Linearity Check

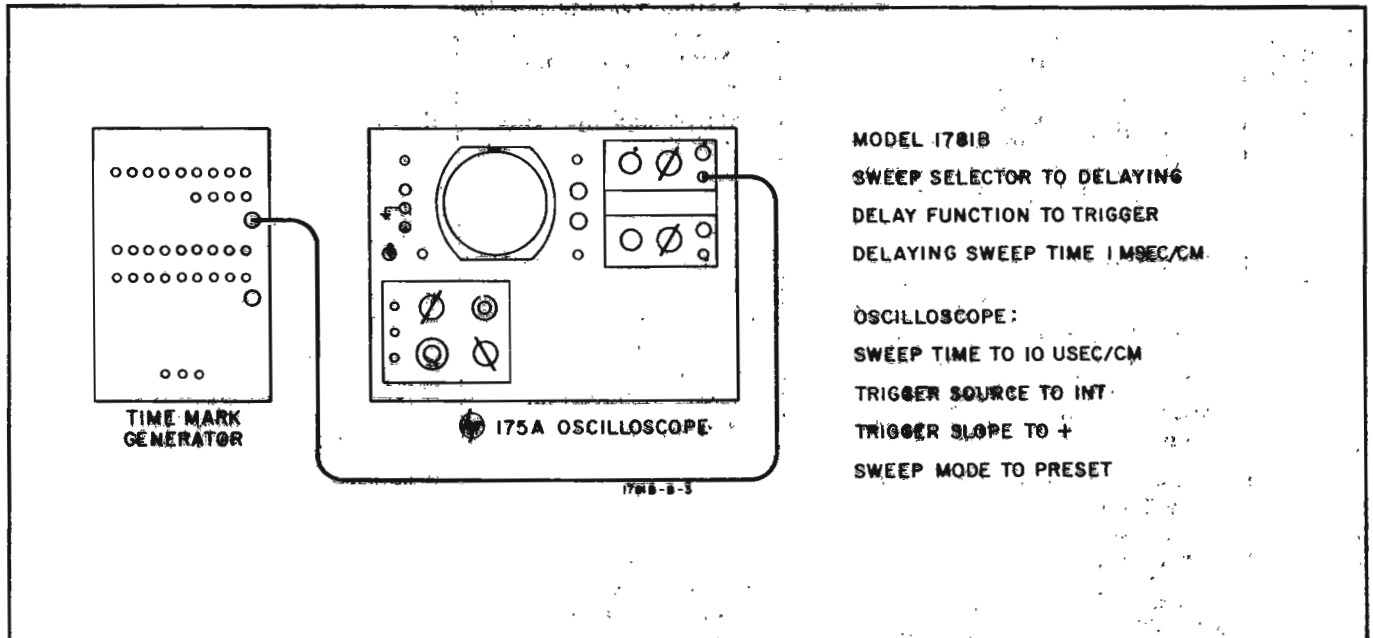

Step	Preliminary Action	Read Indication On	Performance Standard
1	Connect Time-Mark Generator (1 millisecond markers) to Oscilloscope vertical INPUT. Adjust TRIGGER LEVEL controls for stable sweep. Align markers with graticule. Adjust DELAY LENGTH to put brightened part of trace under second marker. Set SWEEP SELECTOR to MAIN DELAYED and adjust DELAY LENGTH to put leading edge of marker at start of trace. Record DELAY LENGTH setting.	DELAY LENGTH dial	
2	Repeat for remaining markers (third through eleventh).	DELAY LENGTH dial	
3	Plot deviation from integral number on DELAY LENGTH dial versus marker as shown below. Draw a straight line such that there is a minimum vertical distance from each point to the line (see example below).	DELAY LENGTH dial	No point may deviate vertically from the line by more than two minor dial divisions.

Example:

Marker Number	DELAY LENGTH	Deviation Minor Divisions
2	0.995	-.5
3	1.998	-.2
4	3.00	0
5	4.001	+.1
6	5.002	+.2
7	6.003	+.3
8	7.003	+.3
9	8.002	+.2
10	9.00	0
11	9.997	-.3

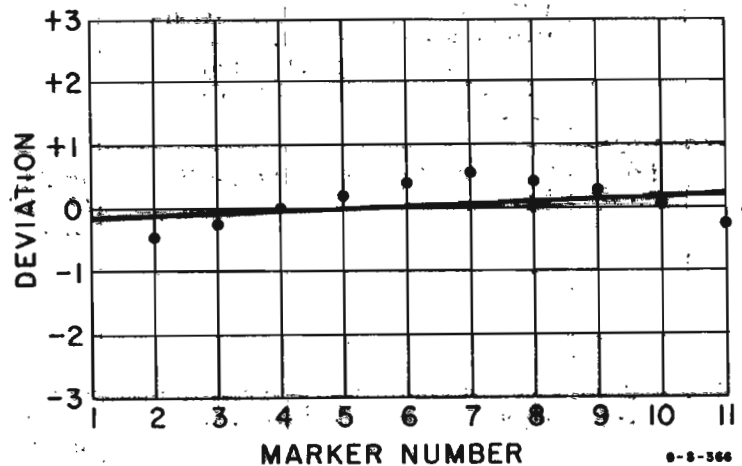

Table 5-5. System Troubleshooting

Step	Preliminary Action	Normal Indication	Next Step
1	Set Model 1781B SWEEP SELECTOR to MAIN and check oscilloscope for proper operation. Refer to oscilloscope manual.	Oscilloscope operates normally	If necessary, troubleshoot oscilloscope. Refer to oscilloscope manual. If oscilloscope operates normally proceed to step 2.
2	Model 1781B: Set SWEEP SELECTOR to DELAYING, DELAY LENGTH to about 4 CM, DELAY FUNCTION to TRIGGER, DELAYING SWEEP TIME to .5 MSEC/CM, and SWEEP MODE to FREE RUN. On oscilloscope set SWEEP MODE to PRESET and SWEEP TIME to .1 MSEC/CM.	Delaying sweep appears on crt with 2-cm brightened segment approximately centered on trace.	If indication is normal, proceed to step 3. If neither delaying sweep nor brightened segment appears, check delaying sweep generator. Refer to table 5-7. If brightened segment does not appear, check delay trigger generator. Refer to table 5-8.
3	Change Model 1781B SWEEP MODE to PRESET, TRIGGER SOURCE to EXT. AC, TRIGGER SLOPE to +, and TRIGGER LEVEL LEVEL to about 0. Connect oscilloscope 1 volt CALIBRATOR terminal to EXT. INPUT of MODEL 1781B.	Delaying sweep appears on crt with 2-cm brightened segment approximately centered on trace.	If indication is normal, all circuits are functioning. Check instrument performance as outlined in paragraph 5-5. If no sweep appears refer to table 5-6.

Table 5-6. Delaying Sweep Trigger Circuits Troubleshooting



Step	Test Point	Preliminary Action	Normal Indication	Next Step
1		Set TRIGGER SOURCE to EXT AC, TRIGGER LEVEL to 0, and SWEEP SELECTOR to MAIN. On oscilloscope, set SWEEP TIME to .5 MSEC/CM, TRIGGER SOURCE to INT, SWEEP MODE to PRESET Connect CALIBRATOR 1 VOLT output to Model 1781B EXT. INPUT. Observe waveform at test point A. Use probe and set vertical sensitivity for adequate deflection on crt. Some adjustment of TRIGGER LEVEL controls may be necessary.	As indicated on schematic diagram figure 5-9	If indication is normal proceed to step 2. If no signal is present, proceed to step 3.
2		Observe waveform at test point B2.	Negative pulses about 10 volts peak.	If indication is normal, delaying sweep trigger circuits are operating properly. If pulses are low in amplitude, check CR2, T1. If positive pulses have nearly equal amplitude, check CR2.
3		Observe waveform at test point A1.	Square wave about 0.4 volts peak-to-peak	If indication is normal, check Q1 circuit. If signal is low in amplitude, check CR1 circuit.

Table 5-7. Delaying Sweep Generator Troubleshooting

Step	Test Point	Preliminary Action	Normal Indication	Next Step
1	☆ B	Set DELAYING SWEEP to 1 SEC/CM and SWEEP MODE to FREE RUN. Measure voltage at test point B.	Voltage should cycle as shown on schematic diagram, figure 5-9, every 10 seconds.	If indication is normal, sweep generator is operating. Check V6 if delaying sweep still does not appear on crt. If voltage remains negative, proceed to step 2. If voltage remains positive, proceed to step 3.
2	⊙ B1 thru ⊙ B9	Measure voltages at test points B1 through B9.	Voltages B3 and B4 should be at the more positive value shown on schematic diagram. Voltage at B5 should be at more negative value. Other voltages should be progressing toward end-of-sweep value. Since sweep is inoperative, these voltages may have progressed beyond end-of-sweep values.	Check first circuit giving incorrect indication.
3	⊙ B1 thru ⊙ B9	Set SWEEP MODE to 12 o'clock Measure voltage at test points B8 and B9, then B1 through B7.	Voltages at B3 and B4 should be at the more negative value shown on schematic diagram. Voltage at B5 should be at more positive value. Voltages at B6 and B7 should be at pre-sweep levels. Since voltage at B is at positive extreme, voltages at B8 and B9 should also be at positive extreme.	Check circuit giving incorrect indication.

Table 5-8. Delay Trigger Generator Troubleshooting

Step	Test Point	Preliminary Action	Normal Indication	Next Step
1	☆ C	Set SWEEP SELECTOR to DELAYING, DELAY LENGTH to about 4 CM, DELAYING SWEEP to 50 μSEC/CM, and SWEEP MODE to FREE RUN. Observe waveform at test point C. Use probe and set vertical sensitivity for adequate deflection on crt.	Positive pulse about 10 volts peak as shown on schematic diagram. Pulse position shifts with DELAY LENGTH setting.	If indication is normal, delay trigger generator is operating properly. If pulse does not appear, proceed to step 2.
2	⊙ C1 thru ⊙ C4	Observe waveforms at test points C1 through C4.	As indicated on schematic diagram	Check first circuit giving incorrect waveform

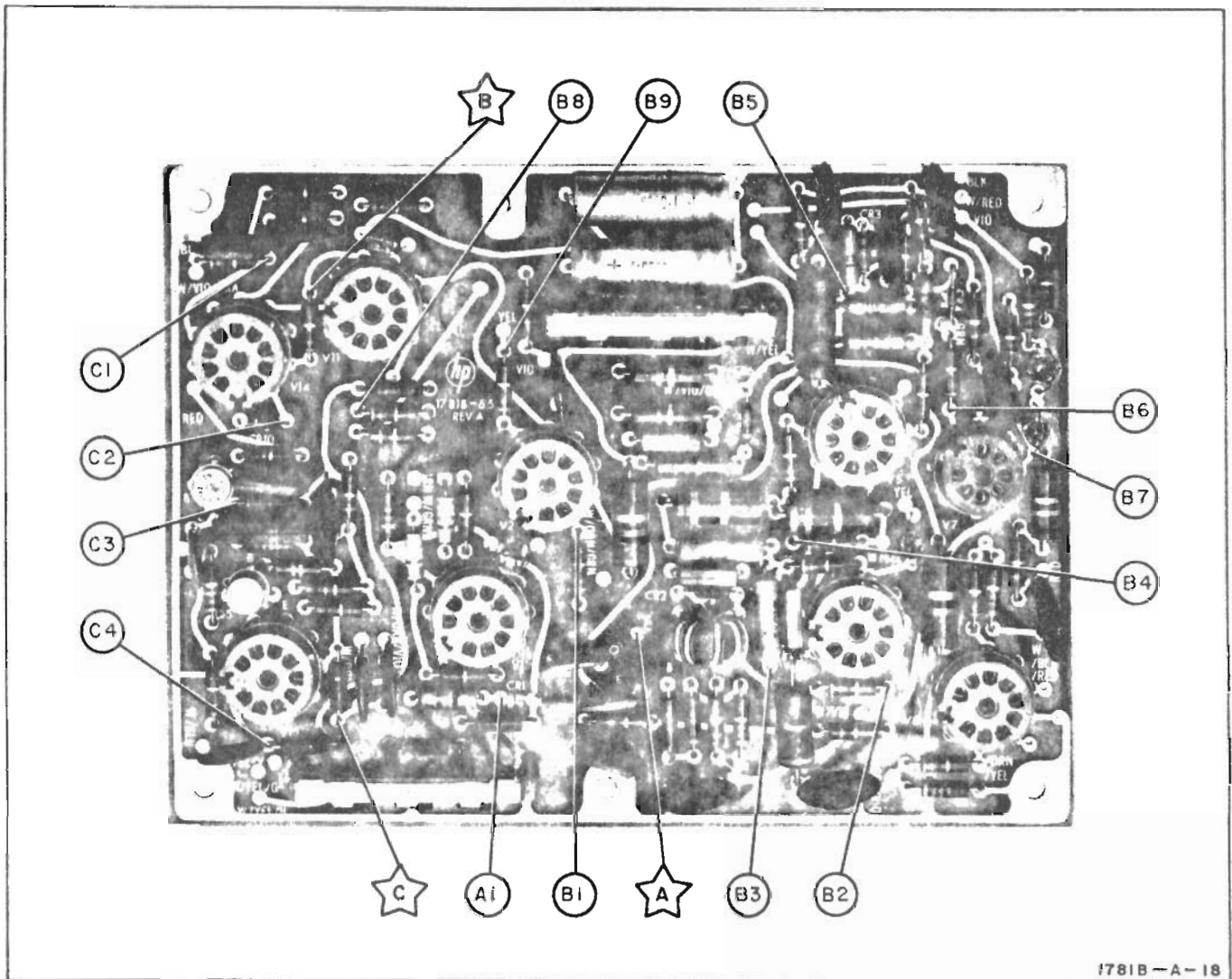

Figure 5-2. Location of Test Points

5-18. PRESET ADJUST.

- a. Set Model 175A:
 SWEEP MODE PRESET
 SWEEP TIME1 μSEC/CM
- b. Set Model 1781B (no signal applied):
 DELAYING SWEEP TIME 1 MSEC/CM
 SWEEP MODE PRESET
 TRIGGER LEVEL Fully CW
 SWEEP SELECTOR DELAYING
 DELAY FUNCTION TRIGGER
- c. Connect dc voltmeter between pin 3 of V2 and ground.
- d. Start with Preset R60 (see figure 5-3 for location) fully ccw and rotate adjustment slowly observing the voltmeter indication. Voltmeter indication will change suddenly as the sweep triggers. Note this maximum negative voltage reading.
- e. Rotate R60 back ccw, then cw again to set a voltage reading 2.5 volts less negative than the voltage noted in step d. About -40 volts is a typical value.

5-19. TRIGGER SENSITIVITY AND SYMMETRY.

- a. Set Model 175A w/plug-in:
 SWEEP MODE PRESET
 SWEEP TIME1 μSEC/CM
 Vertical SENSITIVITY05 VOLTS/CM
 Signal Input AC
- b. Set Model 1781B:
 SWEEP MODE PRESET
 TRIGGER SLOPE -
 TRIGGER SOURCE EXT. AC
 DELAYING SWEEP TIME 1 MSEC/CM
- c. Rotate R18, Trigger Sensitivity, fully cw and center R16, Trigger Symmetry.
- d. Connect 10003 10:1 probe from vertical plug-in to the case of tunnel diode CR1. CAUTION: 110 volts at this point. Figure 5-8 shows CR1 location.
- e. Connect 50 mv rms 400 cps signal from Voltmeter Calibrator to EXT. INPUT.

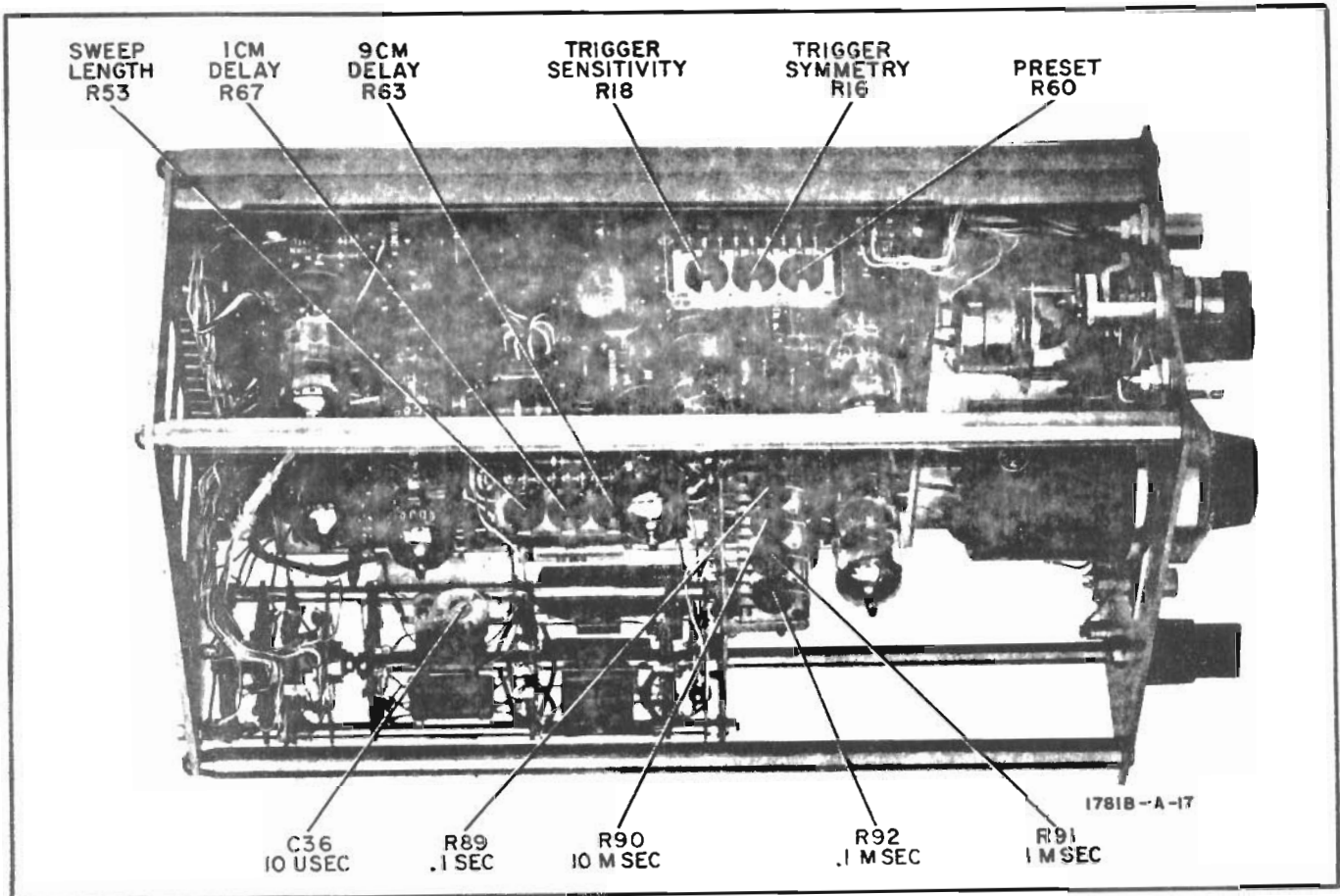

Figure 5-3. Location of Adjustments

f. Rotate Model 1781B TRIGGER LEVEL to obtain display shown in figure 5-4a.

g. Use TRIGGER LEVEL to maintain display and adjust R18 to obtain a stable square wave as in figure 5-4b.

h. Set Voltmeter Calibrator output to 30 mv rms. No pattern should be obtained when TRIGGER LEVEL is rotated. Set voltage to 50 mv rms and display should be steady with proper TRIGGER LEVEL setting. If necessary readjust R18 and repeat.

i. Set Voltmeter Calibrator output to 200 mv p-p.

j. Ground junction of R6 and R9 (see figure 5-5 for location).

k. Adjust R16 for a symmetrical tunnel diode output as in figure 5-4b.

m. Remove grounding lead from R6-R9 and adjust TRIGGER LEVEL for a symmetrical display.

n. Set TRIGGER SLOPE to +. Tunnel diode output displayed should remain about symmetrical.

5-20. SWEEP LENGTH ADJUST.

a. Set Model 175A and vertical plug-in controls as in paragraphs 5-19a.

- b. Set Model 1781B:
 SWEEP MODE PRESET
 SWEEP SELECTOR DELAYING
 DELAYING SWEEP TIME 1 MSEC/CM
 TRIGGER SOURCE INT.

c. Connect oscillator output to vertical plug-in input. Set oscillator frequency to 600 kc and adjust amplitude for a display 5 cm high.

d. Position display so start of sweep pattern is at left graticule line.

e. Adjust Model 1781B TRIGGER LEVEL for shortest possible sweep.

f. Adjust R53, Sweep Length, for a sweep display length of 10.2 cm.

5-21. SWEEP CALIBRATION.

- a. Set Model 175A and vertical plug-in:
 Vertical SENSITIVITY 2 VOLTS/CM
 SWEEP MODE PRESET
 TRIGGER SLOPE +
 TRIGGER SOURCE INT.

- b. Set Model 1781B:
 SWEEP SELECTOR DELAYING
 SWEEP MODE PRESET
 DELAY FUNCTION TRIGGER
 TRIGGER SOURCE INT.

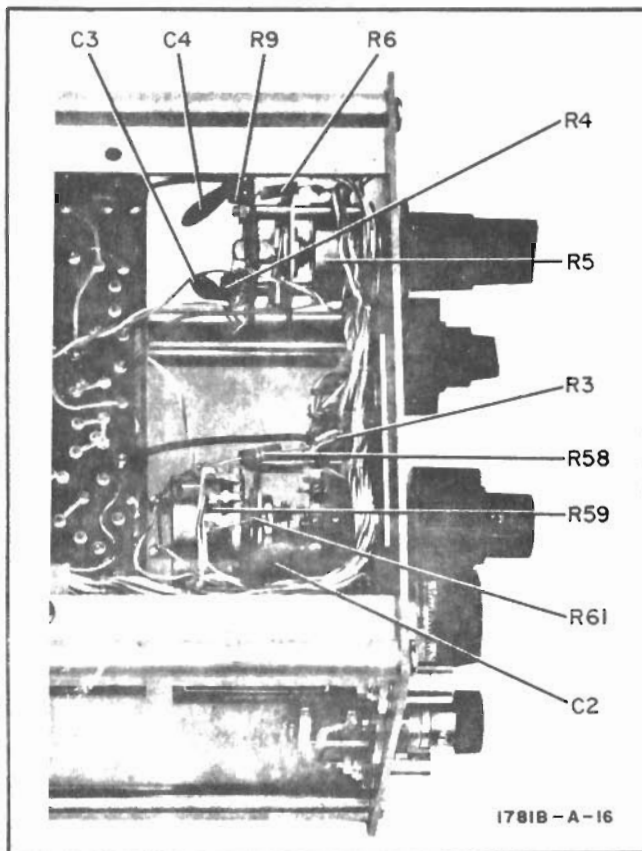

Figure 5-4. Trigger Adjustment Waveforms

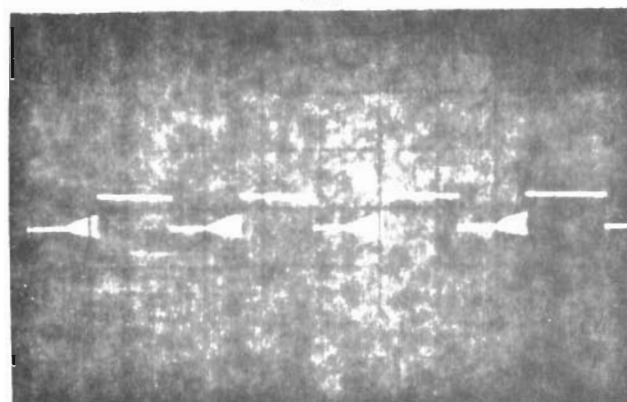
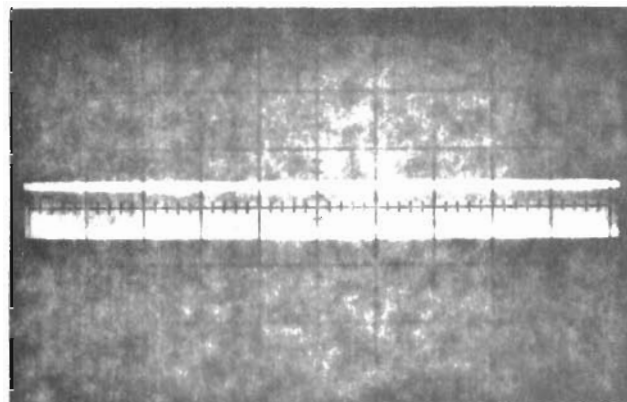

Figure 5-5. Location of Parts Mounted on Switch Assemblies A3 and A4

c. Connect Time-Mark Generator to oscilloscope vertical plug-in.

d. Refer to table 5-9 for adjustments and settings. Set Model 175A SWEEP TIME at least four ranges faster than the Model 1781B DELAYING SWEEP TIME. Use the HORIZONTAL POSITION control to align the first marker with the left edge of the graticule, adjust component indicated to align the eleventh marker with the right edge of the graticule.

5-22. DELAY LENGTH-DELAYING SWEEP ADJUST.

- a. Set Model 175A:
SWEEP MODE PRESET
SWEEP TIME 10 μSEC/CM

- b. Set Model 1781B:
SWEEP SELECTOR MAIN DELAYED
DELAYING SWEEP TIME 1 MSEC/CM
SWEEP MODE PRESET
TRIGGER SLOPE +
TRIGGER SOURCE INT.
DELAY FUNCTION TRIGGER

c. Set Time-Mark Generator for 1 ms markers and connect the output to the oscilloscope vertical plug-in.

d. Set Model 1781B DELAY LENGTH to 1.00 CM. Adjust R67, 1 Cm Delay to set start of second marker at the beginning of sweep (on left). Switching to DELAYING will always show which marker is being displayed (brightened part of trace).

e. Set DELAY LENGTH to 9.00 CM. Adjust R63, 9 Cm of Delay, to set start of tenth marker to beginning of sweep. Adjustment of R63 and R67 interact. Repeat above procedure as necessary.

Note: Before completing this procedure, be sure the Model 175A horizontal amplifier is adjusted correctly. Refer to Model 175A Operating and Service Manual for procedure.

f. Set Model 1781B DELAYING SWEEP TIME to 50 μSEC/CM and SWEEP SELECTOR to MAIN DELAYED. Change Time-Mark Generator to 50 μsec markers. Keep Model 175A SWEEP TIME at least four ranges faster than the Model 1781B.

Table 5-9. Sweep Calibration

DELAYING SWEEP TIME Setting:	Time-Mark Generator	Adjust.
5 μsec/cm	5 μsec	C36
50 μsec/cm	50 μsec	R92
.5 μsec/cm	500 msec.	R91
5 msec/cm	5 msec.	R90
.1 sec/cm	100 msec.	R89

g. Set DELAY LENGTH so leading edge of second marker is at beginning of trace. DELAY LENGTH setting should be approximately 1 CM.

h. Increase DELAY LENGTH setting by exactly 9 cm (e.g. from 0.97 to 9.97). Adjust R92 to place leading edge of eleventh marker at beginning of trace. Repeat for no interaction.

i. Change DELAYING SWEEP TIME to 5 μSEC/CM (also change Model 175A to faster sweep) and use 5 μsec markers. Repeat steps g and h, adjusting C36 as required.

j. Check accuracy of DELAYING SWEEP TIME as specified in table 5-3. It may be necessary to make a slight readjustment of R89, R90, R91, R92, or C36 to meet these specifications.

5-23. CONDENSED ADJUSTMENT PROCEDURE.

5-24. Table 5-10 provides a condensed adjustment procedure for the Model 1781B. This table summarizes the procedures of paragraphs 5-18 through

Table 5-10. Model 1781B Condensed Adjustment Procedure

Adjustment	Equipment Required	Procedure	Adjustment and Indication																		
1. Preset	DC Voltmeter	a. DELAY FUNCTION TRIGGER SWEEP SELECTOR DELAYING SWEEP TIME · 1 MSEC/CM TRIGGER LEVEL fully cw SWEEP MODE PRESET b. Connect Voltmeter to pin 3 of V2. c. Start R60 fully ccw and note maximum negative reading while rotating R60 cw.	R60 for reading 2.5 volts less negative than voltage noted.																		
2. Trigger Sensitivity	Voltmeter Calibrator	a. Apply 50 mv rms, 400 cps signal to EXT. INPUT. b. SWEEP MODE PRESET Trigger Sensitivity R18 cw Trigger Symmetry R16 centered DELAYING SWEEP TIME · 1 MSEC/CM c. Connect probe from vertical INPUT to case of CR1, SENSITIVITY 0.05 VOLTS/CM.	a. TRIGGER LEVEL for free-running display. b. Adjust R18 (with TRIGGER LEVEL) for stable square wave. c. If necessary, rotate R18 ccw to prevent solid triggering on 30 mv rms input.																		
3. Trigger Symmetry	Voltmeter Calibrator	a. Same settings and oscilloscope probe connection as for Trigger Sensitivity adjust. b. Ground pin 7 of V1B. c. 200 mv p-p signal to EXT. INPUT.	R16 for symmetrical square wave. (Remove ground from pin 7.)																		
4. Sweep Length	Oscillator	Display 600 Kc signal at DELAYING SWEEP TIME of 1 MSEC/CM.	Set TRIGGER LEVEL for shortest sweep and adjust R53 for 10.2 cm sweep length.																		
5. Sweep Calibration	Time Mark Generator	a. Connect Time Mark Generator to vertical INPUT. b. TRIGGER SOURCE INT SWEEP SELECTOR DELAYING SWEEP MODE PRESET c. Align 1st marker with left edge of graticule.																			
		<table border="1"> <thead> <tr> <th>DELAYING SWEEP TIME</th> <th>Markers</th> <th>Adjust for 11th marker at right edge of graticule</th> </tr> </thead> <tbody> <tr> <td>5 μSEC/CM</td> <td>5 μsec</td> <td>C36</td> </tr> <tr> <td>50 μSEC/CM</td> <td>50 μsec</td> <td>R92</td> </tr> <tr> <td>0.5 MSEC/CM</td> <td>500 μsec</td> <td>R91</td> </tr> <tr> <td>5 MSEC/CM</td> <td>5 msec</td> <td>R90</td> </tr> <tr> <td>0.1 SEC/CM</td> <td>100 msec</td> <td>R89</td> </tr> </tbody> </table>	DELAYING SWEEP TIME	Markers	Adjust for 11th marker at right edge of graticule	5 μSEC/CM	5 μsec	C36	50 μSEC/CM	50 μsec	R92	0.5 MSEC/CM	500 μsec	R91	5 MSEC/CM	5 msec	R90	0.1 SEC/CM	100 msec	R89	
		DELAYING SWEEP TIME	Markers	Adjust for 11th marker at right edge of graticule																	
5 μSEC/CM	5 μsec	C36																			
50 μSEC/CM	50 μsec	R92																			
0.5 MSEC/CM	500 μsec	R91																			
5 MSEC/CM	5 msec	R90																			
0.1 SEC/CM	100 msec	R89																			

Table 5-10. Model 1781B Condensed Adjustment Procedure (Cont'd)

Adjustment	Equipment Required	Procedure	Adjustment and Indication
6. Delay Length	Time Mark Generator	<p>a. DELAYING SWEEP TIME · 1 MSEC/CM SWEEP SELECTOR · · MAIN DELAYED DELAY FUNCTION · · · · · TRIGGER SWEEP MODE · · · · · PRESET TRIGGER SOURCE · · · · · INT. TRIGGER SLOPE · · · · · +</p> <p>b. Model 175A SWEEP TIME · 10 μSEC/CM</p> <p>c. Display 1 msec markers.</p>	<p>a. DELAY LENGTH · · 1.00</p> <p>b. R67 to set 2nd marker at beginning of sweep. (Use DELAYING sweep to identify marker.)</p> <p>c. DELAY LENGTH · · 9.00</p> <p>d. R63 to set 10th marker at beginning of sweep.</p> <p>e. Repeat steps a thru d for no interaction.</p>
7. Delaying Sweep	Time Mark Generator	<p>a. Same control settings as for Delay Length adjust except: DELAYING SWEEP TIME · · 50 μSEC/CM SWEEP SELECTOR · · MAIN DELAYED</p> <p>b. Display 50 μsec markers. See step a in adjustment column.</p> <p>c. DELAYING SWEEP TIME · · 5 μSEC/CM</p> <p>d. Display 5 μsec markers. See step f in adjustment column.</p>	<p>a. DELAY LENGTH: to set 2nd marker at beginning of sweep.</p> <p>b. Increase DELAY LENGTH reading by 9.00 cm.</p> <p>c. Adjust R92 to set 11th marker at beginning of sweep.</p> <p>d. Repeat steps a thru c for no interaction.</p> <p>e. See step c in procedure column.</p> <p>f. Repeat steps a thru d above, adjusting C36 as required.</p>

5-22 and should not be used until the detailed procedures are familiar. The test equipment specified in table 5-10 is the same as for the detailed procedures and is listed in table 5-1.

5-25. REPAIR AND REPLACEMENT.

5-26. REPLACING COMPONENTS.

5-27. Components on the etched circuit assemblies (A1 and A2) may be replaced by observing servicing techniques outlined in this paragraph. Components on assembly A1 are identified in figure 5-8. Components on switch assemblies are identified in figures 5-5, 5-6, and 5-7. Electrical components mounted on the plug-in front panel can be identified by noting the schematic reference designation and its corresponding front panel label. Replaceable parts information for all components is included in section VI. Proceed as follows:

a. Before attempting a repair, determine the nature and location of the fault; unnecessary replacement complicates the repair procedure. Do not repair or replace any part unless it is proved necessary. (Be sure the trouble cannot be cleared by an adjustment.)

b. Servicing with Model 1781B installed in the oscilloscope requires special precautions. Do not solder with the power turned on. Unplug the oscilloscope from the power line to protect the semiconductors against excessive leakage current.

c. In soldering a semiconductor, apply a heat sink, such as a pair of pliers, between the semiconductor and the hot iron.

d. Avoid using a high-power soldering iron on the etched circuit boards. Excessive heat and pressure may lift a copper strip or warp the board, increasing susceptibility to mechanical damage. A lifted strip may be recemented with a quick-drying acetate cement having a good electrical insulation characteristic. A broken strip may be joined by a strip of tinned copper wire.

e. To remove a component fitting tightly in a multiple-pin socket, such as a tube, a connector, etc., loosen gently by working it gradually around from one side to the other.

f. To remove a faulty multi-pin component such as a transformer, tube socket or potentiometer, clip the pins and remove the component. Then remove the pins one by one. If this procedure is not convenient, use a cup-tip soldering iron.

g. Clean the repaired area and coat it with a high-quality electrical varnish or lacquer for protection against contamination and corrosion.

5-28. ADJUSTMENTS AFTER REPLACEMENT.

5-29. Table 5-11 lists the adjustments required following tube, transistor, or diode replacement. These adjustments may be necessary following component replacement in an associated circuit.

Table 5-11. Adjustments Required Following Tube, Transistor, or Diode Replacement

Tube or Transistor	Function	Adjustment	Paragraph
CR1	Trigger Generator	Trigger Sensitivity and Symmetry	5-19
CR2	Limiter	None	
CR3	Limiter	None	
CR4	Switch Diode	Sweep Calibration	5-21
CR5	Turn on Protection	Sweep Calibration	5-21
CR6	Sweep Mixing Diode	None	
CR10	Coupling Diode	Sweep Calibration	5-21
		Delay Length-Delaying Sweep	5-22
V1	Trigger Amplifier	Trigger Symmetry, Trigger Sensitivity	5-19
V2	Bias Control Cathode Follower	None	
V3	Gate Generator	Preset	5-18
V5	Gate Generator/Clamp	Preset	5-18
V6	Cathode Follower	None	
V7	Integrator	Sweep Calibration	5-21
V11	Cathode Follower	None	
V14	Comparator	Delay Length-Delaying Sweep	5-22
V15	Current Source/Phase Splitter	None	
Q5	Current Source	Delay Length-Delaying Sweep: steps a thru e	5-22
Q6	Amplifier	Delay Length-Delaying Sweep	5-22

**Table 5-12. Calibration and Component Replacement Record
For Hewlett-Packard Company Model 1781B Delay Generator**

Instrument Serial No. _____

CALIBRATION

Date	Description of Calibration Made	Paragraph Procedure(s) Used

COMPONENT REPLACEMENT

Date	Component Designator	Nature of Failure

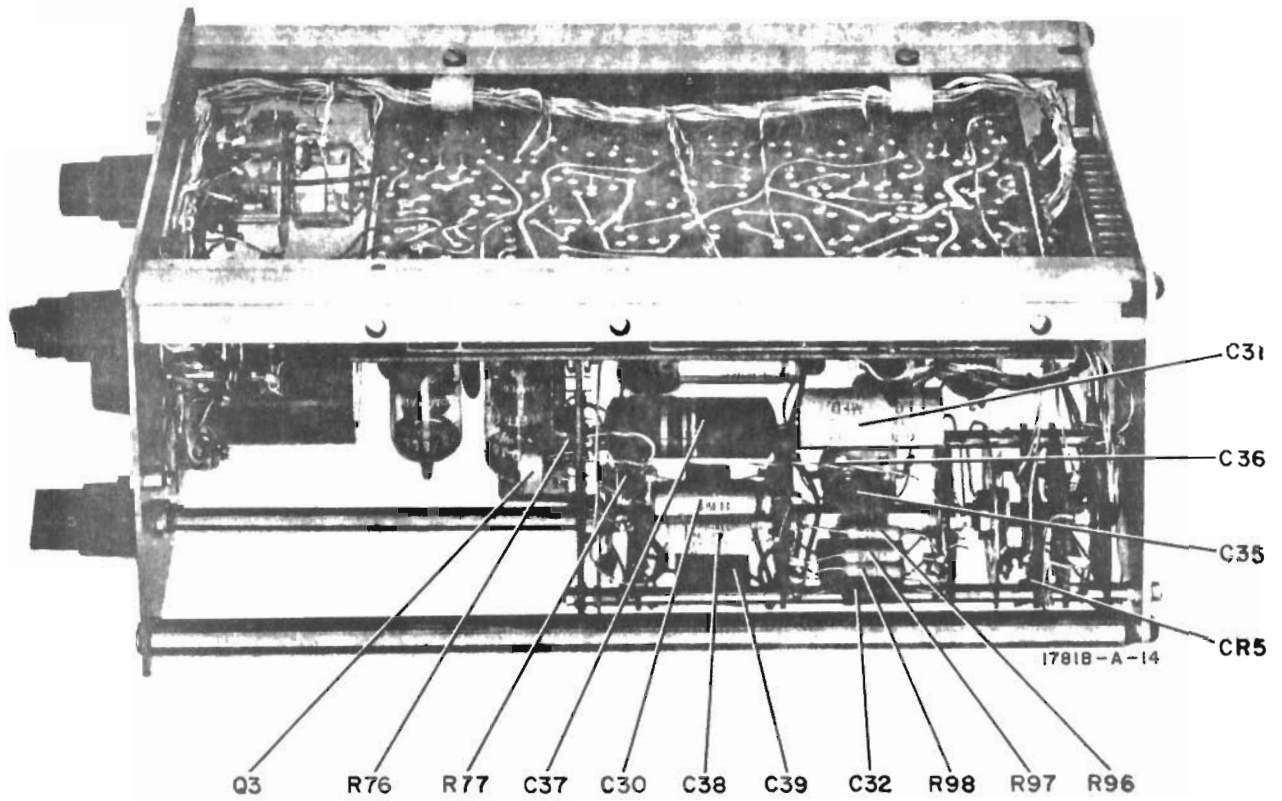

Figure 5-6. Location of Parts on Sweep Time Switch, Right View

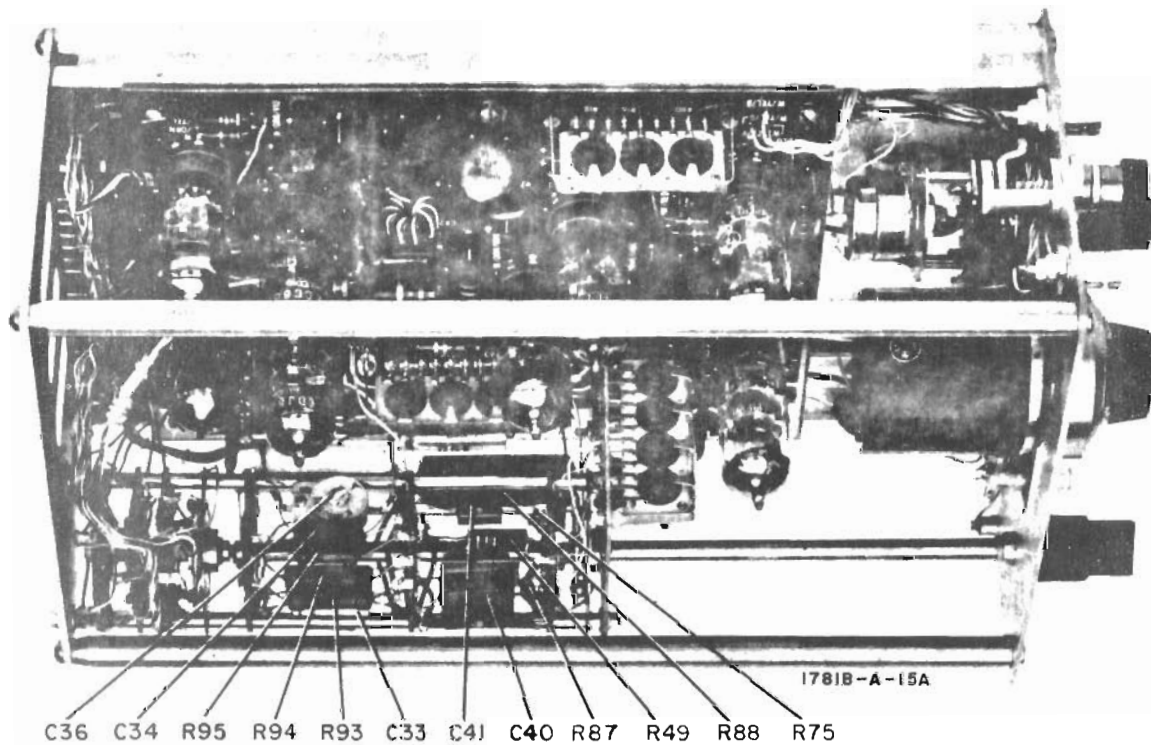
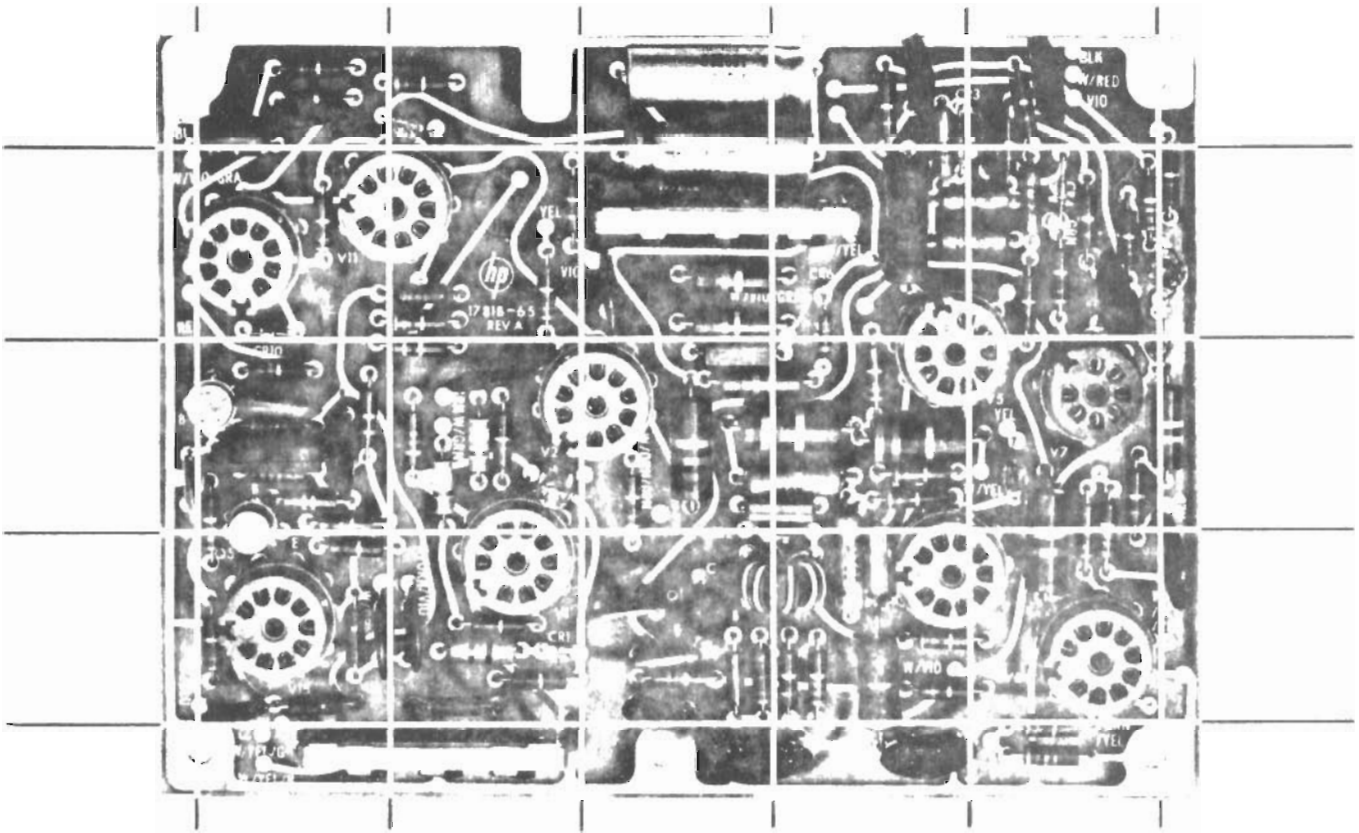

Figure 5-7. Location of Parts on Sweep Time Switch, Left View



* LOCATION OF R49 ONLY FOR INSTRUMENTS WITH SERIAL PREFIXES OF 305-, 309-, 320-, AND 412-.

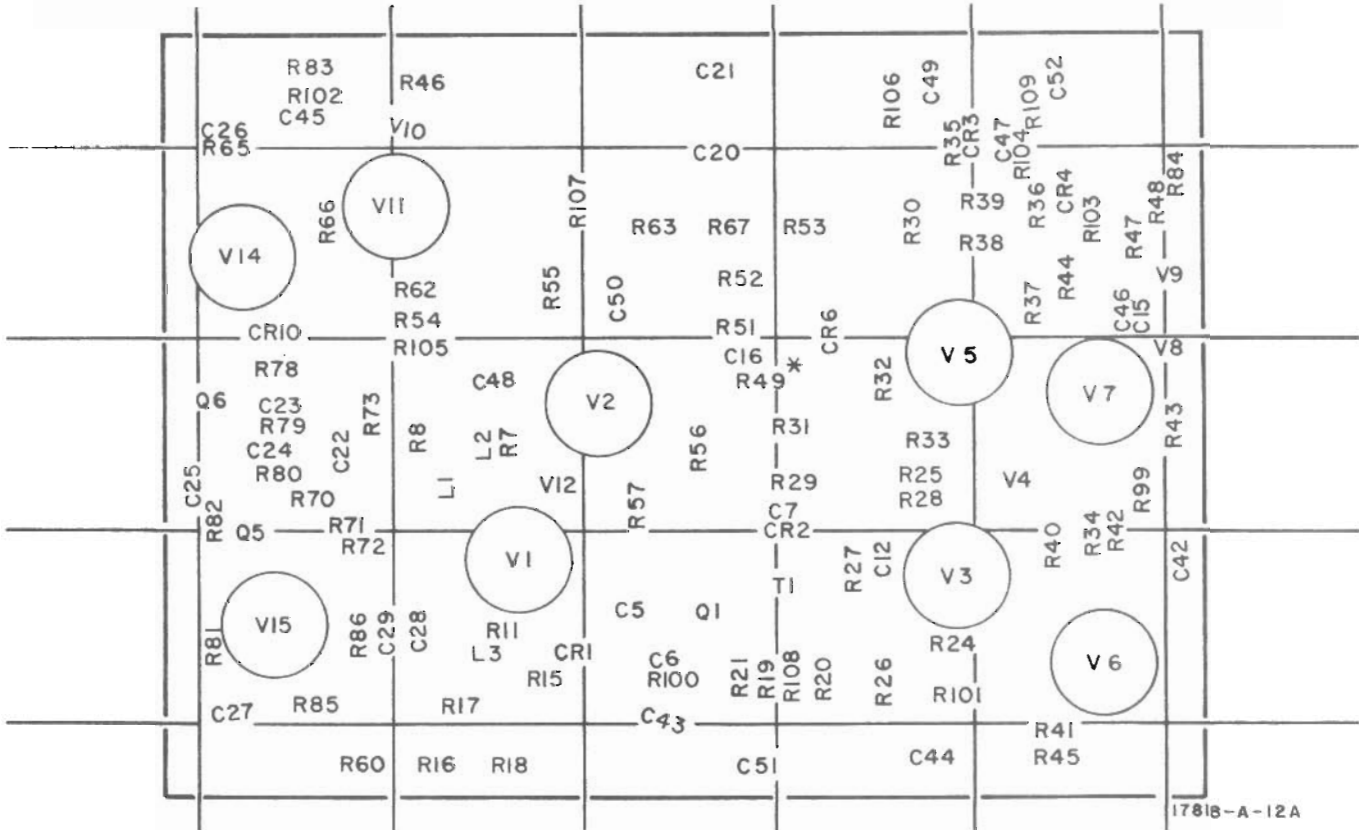
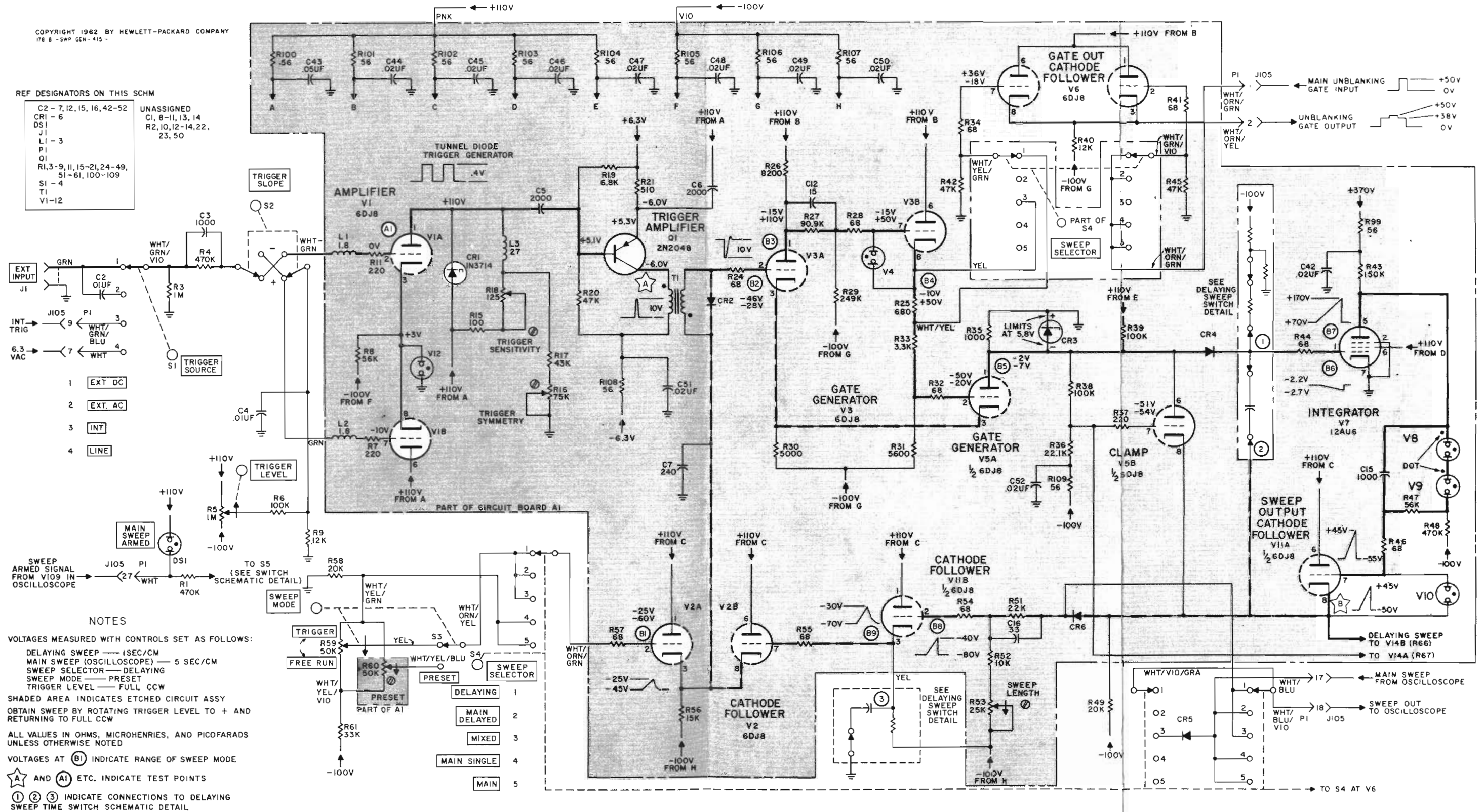

Figure 5-8. Location of Parts on Circuit Board

COPYRIGHT 1962 BY HEWLETT-PACKARD COMPANY
178 B - SWP GEN - 415 -

REF DESIGNATORS ON THIS SCHM

C2 - 7, 12, 15, 16, 42-52	UNASSIGNED
CR1 - 6	C1, 8-11, 13, 14
DS1	R2, 10, 12-14, 22, 23, 50
J1	
L1 - 3	
P1	
Q1	
R1, 3-9, 11, 15-21, 24-49, 51-61, 100-109	
S1 - 4	
T1	
V1-12	



NOTES

VOLTAGES MEASURED WITH CONTROLS SET AS FOLLOWS:
 DELAYING SWEEP — 1 SEC/CM
 MAIN SWEEP (OSCILLOSCOPE) — 5 SEC/CM
 SWEEP SELECTOR — DELAYING
 SWEEP MODE — PRESET
 TRIGGER LEVEL — FULL CCW

SHADED AREA INDICATES ETCHED CIRCUIT ASSY
 OBTAIN SWEEP BY ROTATING TRIGGER LEVEL TO + AND RETURNING TO FULL CCW

ALL VALUES IN OHMS, MICROHENRIES, AND PICOFARADS UNLESS OTHERWISE NOTED

VOLTAGES AT (B) INDICATE RANGE OF SWEEP MODE

(A) AND (A1) ETC. INDICATE TEST POINTS

(1) (2) (3) INDICATE CONNECTIONS TO DELAYING SWEEP TIME SWITCH SCHEMATIC DETAIL

Figure 5-9. Sweep Generator
5-15

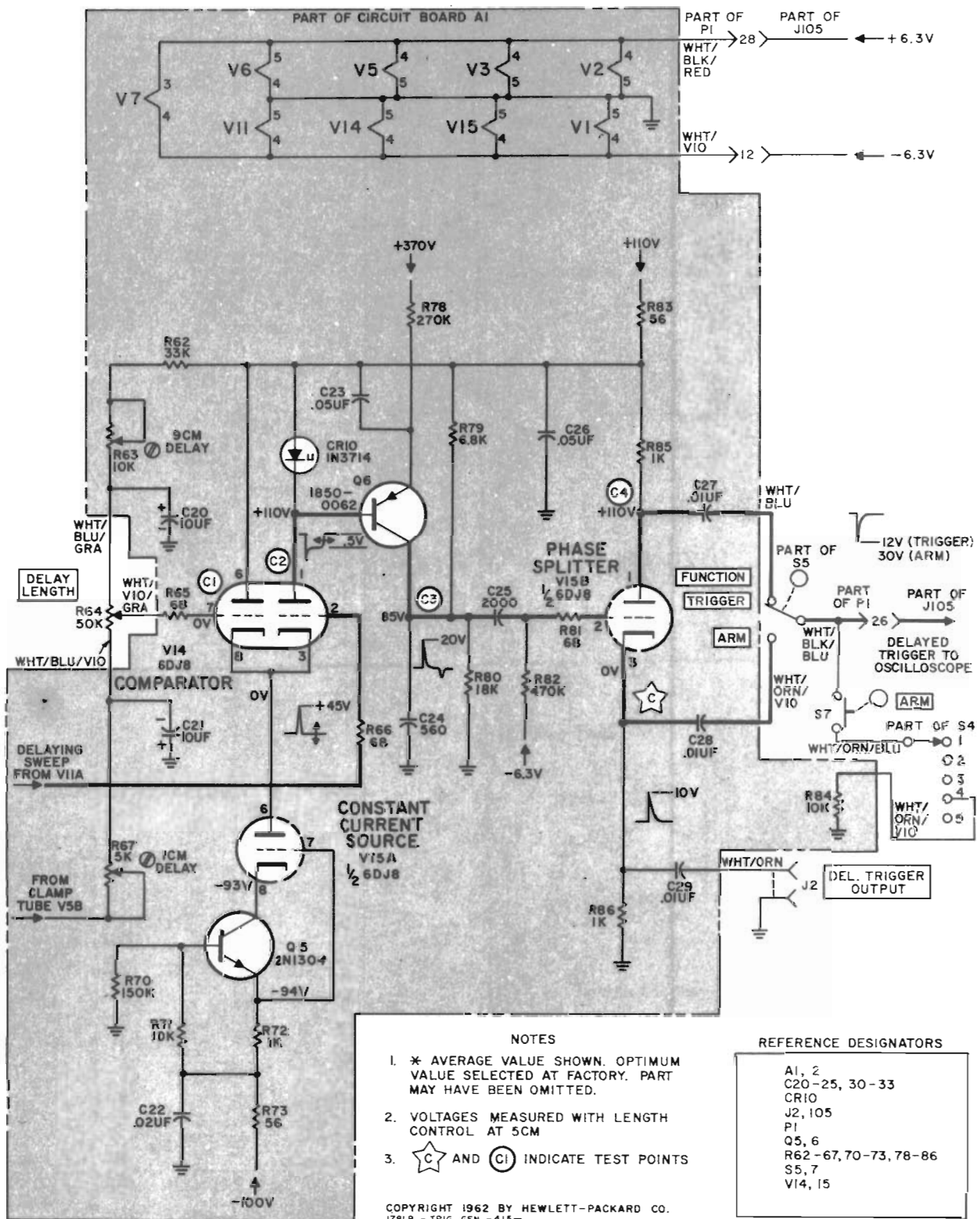

Figure 5-10. Delayed Trigger Generator

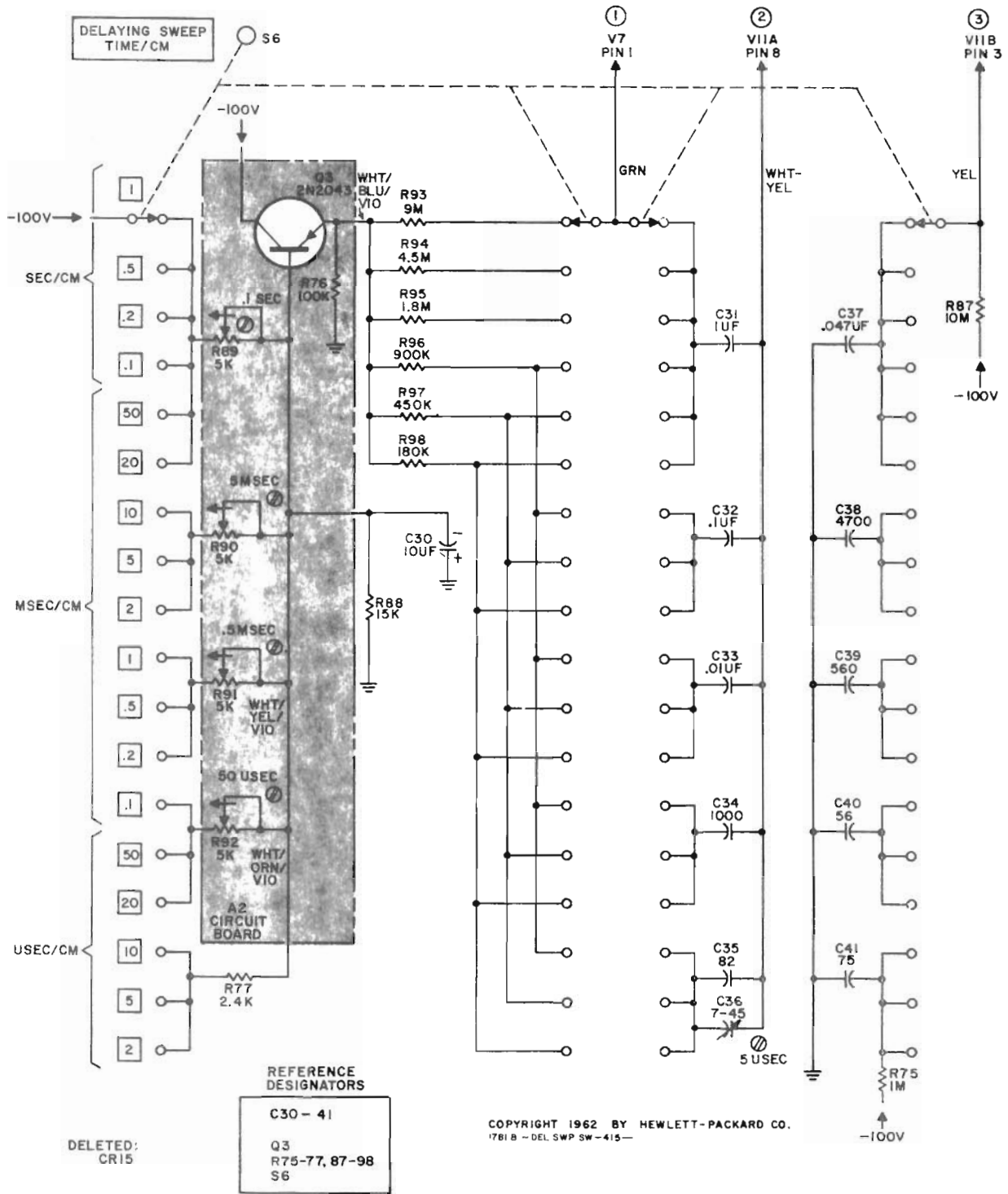
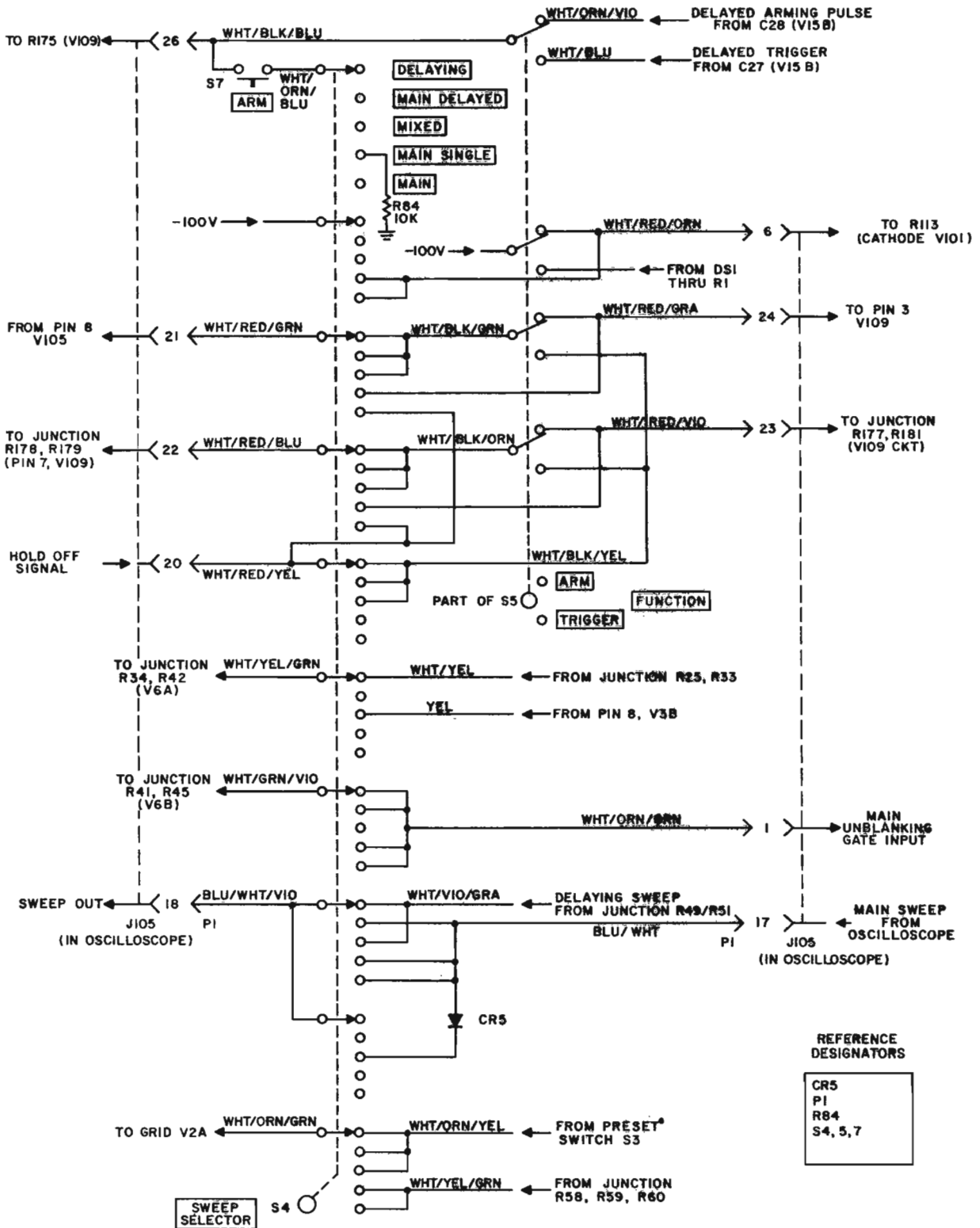

Figure 5-11. Delaying Sweep Time Switch



COPYRIGHT 1962 BY HEWLETT-PACKARD CO.
1781B - SWR SEL. SW. - 412

Figure 5-12. Sweep Selector and Delay Function Switches

SECTION VI REPLACEABLE PARTS

6-1. INTRODUCTION.

6-2. This section contains information for ordering replacement parts. Table 6-1 lists parts in alpha-numerical order of their reference designators and indicates the description and stock number of each part, together with any applicable notes. Table 6-2 lists parts in alpha-numerical order of their stock number and provides the following information on each part:

- a. Description of the part (see list of abbreviations below).
- b. Typical manufacturer of the part in a five-digit code; see list of manufacturers in Table 6-3.
- c. Manufacturer's part number.
- d. Total quantity used in the instrument (TQ column).

6-3. Miscellaneous parts are listed at the end of Table 6-1.

6-4. ORDERING INFORMATION.

6-5. To order a replacement part, address order or inquiry to your local Hewlett-Packard Field Office (see maps at rear of this manual for addresses).

6-6. Specify the following information for each part:

- a. Model and complete serial number of instrument.
- b. Hewlett-Packard stock number.
- c. Circuit reference designator.
- d. Description.

6-7. To order a part not listed in Tables 6-1 and 6-2, give a complete description of the part and include its function and location.

REFERENCE DESIGNATORS

A = assembly	F = fuse	P = plug	V = vacuum tube, neon bulb, photocell, etc.
B = motor	FL = filter	Q = transistor	W = cable
C = capacitor	J = jack	R = resistor	X = socket
CR = diode	K = relay	RT = thermistor	Y = crystal
DL = delay line	L = inductor	S = switch	Z = network
DS = device signaling (lamp)	M = meter	T = transformer	
E = misc electronic part	MP = mechanical part		

ABBREVIATIONS

A = amperes	ELECT = electrolytic	MOM = momentary	RH = round head
A.F.C = automatic frequency control	ENCAP = encapsulated	MTG = mounting	RMO = rack mount only
AMP = amplifier		MY = mylar	RMS = root-mean-square
	F = farads	NC = normally closed	ROT = rotary
B.F.O. = beat frequency oscillator	FH = flat head	NE = neon	S-B = slow-blow
BE CU = beryllium copper	FIL H = filister head	NI PL = nickel plate	SE = selenium
BH = binder head	FXD = fixed	NO = normally open	SECT = section(s)
BP = bandpass		NPO = negative positive zero (zero temperature coefficient)	SEMICON = semiconductor
BRS = brass	GE = germanium	NSR = not separately replaceable	SI = silicon
BWO = backward wave oscillator	GL = glass		SIL = silver
	GRD = ground(ed)		SL = slide
CER = ceramic	H = henries	ORD = order by description	SPL = special
CMO = cabinet mount only	HEX = hexagonal	OH = oven head	SST = stainless steel
COEF = coefficient	HG = mercury	OX = oxide	
COM = common	HR = hour(s)		TA = tantalum
COMP = composition			TD = time delay
CONN = connector	IMPG = impregnated	P = peak	TI = titanium
CP = cadmium plate	INCD = incandescent	PC = printed circuit board	TOG = toggle
CRT = cathode-ray tube	INS = insulation(ed)	PF = picofarads = 10 ⁻¹² farads	TOL = tolerance
DEPC = deposited carbon		PH BRZ = phosphor bronze	TRIM = trimmer
EIA = Tubes or transistors meeting Electronic Industries' Association standards will normally result in instrument operating within specifications; tubes and transistors selected for best performance will be supplied if ordered by stock numbers.	K = kilo = 1000	PIV = peak inverse voltage	TWT = traveling wave tube
		POLY = polystyrene	U = micro = 10 ⁻⁶
	LIN = linear taper	POR = porcelain	VAC = vacuum
	LK = lock	POS = position(s)	VAR = variable
	LOG = logarithmic taper	POT = potentiometer	
	LPF = low pass filter	PP = peak-to-peak	W = watts
		PT = point	W/ = with
	M = milli = 10 ⁻³		W/O = without
	MEG = meg = 10 ⁶	RECT = rectifier	WW = wirewound
	METFLM = metal film	RF = radio frequency	
	MFR = manufacturer		
	MINAT = miniature		

01194-8

Table 6-1. Reference Designation Index

Circuit Reference	Ⓢ Stock No.	Description	Note
A1	17818-65A	ASSY:DELAYING SWEEP AND TRIGGER BOARD	
A2	17818-65B	ASSY:SWEEP TIME SWITCH BOARD	
A3	17818-19C	ASSY:TRIGGER SLOPE SWITCH	
A4	17818-19B	ASSY:TRIGGER SOURCE SWITCH	
A5	2100-0406	R:VAR COMP 4 X 5K OHM 30% 1/4W	
A6	17818-19A	ASSY:SWEEP TIME AND SWEEP SELECTOR SWITCH (INCLUDES A2)	
A7	2100-0404	R:VAR COMP 50K-50K-100 OHM 30% 1/4W	
A8	2100-0899	R:VAR COMP 10K-5K-25K OHM 20% 1/4W	
C2	0150-0012	C:FXD CER 0.01 UF 20% 1000VDCW	
C3	0150-0069	C:FXD CER 1000 PF +100-20% 500VDCW	
C4	0150-0012	C:FXD CER 0.01 UF 20% 1000VDCW	
C5	0160-2103	C:FXD CER 2000 PF 20% 1000VDCW	
C6	0160-2103	C:FXD CER 2000 PF 20% 1000VDCW	
C7	0140-0092	C:FXD MICA 240 PF 5% 500VDCW	
C8			
C11		NOT ASSIGNED	
C12		C:FXD MICA 15 PF 5% 500VDCW	
C13	0140-0101		
C14		NOT ASSIGNED	
C15	0150-0069	C:FXD CER 1000 PF +100-20% 500VDCW	
C16	0140-0100	C:FXD MICA 33 PF 5% 500VDCW	
C17	0180-0089	NOT ASSIGNED	
C19		C:FXD ELECT 10 UF +100-10% 150VDCW	
C20			
C21	0180-0089	C:FXD ELECT 10 UF +100-10% 150VDCW	
C22	0150-0070	C:FXD CER 0.02 UF 20% 500VDCW	
C23	0150-0052	C:FXD CER 0.05 UF 20% 400VDCW	
C24	0140-0044	C:FXD MICA 560 PF 10% 500VDCW	
C25	0160-2103	C:FXD CER 2000 PF 20% 1000VDCW	
C26	0150-0052	C:FXD CER 0.05 UF 20% 400VDCW	
C27	0150-0012	C:FXD CER 0.01 UF 20% 1000VDCW	
C28	0150-0012	C:FXD CER 0.01 UF 20% 1000VDCW	
C29	0150-0012	C:FXD CER 0.01 UF 20% 1000VDCW	
C30	0180-0089	C:FXD ELECT 10 UF +100-10% 150VDCW	
C31	0170-0018	C:FXD MY 1 UF 5% 200VDCW	
C32	0170-0019	C:FXD MY 0.1 UF 5% 200VDCW	
C33	0160-0314	C:FXD MY 0.01 UF 5% 400VDCW	
C34	0140-0018	C:FXD MICA 1000 PF 5% 500VDCW	
C35	0140-0006	C:FXD MICA 82 PF 10% 500VDCW	
C36	0130-0001	C: VAR CER 7-45 PF 500VDCW	
C37	0170-0060	C: FXD MY 0.047 UF 10% 400VDCW	
C38	0170-0021	C: FXD MY 4700 PF 10% 400VDCW	
C39	0140-0044	C: FXD MICA 560 PF 10% NPO 500VDCW	
C40	0140-0014	C: FXD MICA 56 PF 10% 500VDCW	
C41	0140-0040	C: FXD MICA 75 PF 5%	
C42	0150-0070	C:FXD CER .02 UF 20% 500VDCW	
C43	0150-0052	C:FXD CER 0.05 UF 20% 400VDCW	
C44	0150-0070	C:FXD CER .02 UF 20% 500VDCW	
C45	0150-0070	C:FXD CER .02 UF 20% 500VDCW	

See introduction to this section

Table 6-1. Reference Designation Index (Cont'd)

Circuit Reference	Stock No.	Description	Note
C46 C52	THRU 0150-0070	C:FXD CER .02 UF 20% 500VDCW	
CR1	1912-0007	SEMICON DEVICE:DIODE 1N3714	
CR2	1901-0040	SEMICON DEVICE:DIODE SILICON	
CR3	1902-0034	SEMICON DEVICE:DIODE,BREAKDOWN	
CR4	1901-0439	SEMICON DEVICE:DIODE SILICON	
CR5	1901-0096	SEMICON DEVICE:DIODE SILICON	
CR6	1901-0096	SEMICON DEVICE:DIODE SILICON	
CR7	THRU		
CR9		NOT ASSIGNED	
CR10	1912-0007	SEMICON DEVICE:DIODE 1N3714	
DS1	1450-0116	LAMP:NEON NE2E	
J1	1250-0083	CONNECTOR:BNC	
J2	1250-0083	CONNECTOR:BNC	
L1	9140-0121	COIL:FXD 1.8 UH	
L2	9140-0121	COIL:FXD 1.8 UH	
L3	9140-0107	COIL:FXD RF 27 UH	
P1	1251-0136	CONNECTOR:MALE 32 PIN	
Q1	1850-0091	TRANSISTOR:GERMANIUM PNP 2N2048	
Q2		NOT ASSIGNED	
Q3	1850-0092	TRANSISTOR:GERMANIUM PNP 2N2043	
Q4		NOT ASSIGNED	
Q5	1851-0017	TRANSISTOR:2N1304	
Q6	1850-0062	TRANSISTOR:GERMANIUM,SPECIAL	
R1	0684-4741	R:FXD COMP 470K OHM 10% 1/4W	
R2		NOT ASSIGNED	
R3	0687-1051	R:FXD COMP 1 MEGOHM 10% 1/2W	
R4	0687-4741	R:FXD COMP 470K OHM 10% 1/2W	
R5		NOT SEPARATELY REPLACEABLE PART OF A3	
R6	0687-1041	R:FXD COMP 100K OHM 10% 1/2W	
R7	0687-2211	R:FXD COMP 220 OHM 10% 1/2W	
R8	0686-5635	R:FXD COMP 56K OHM 5% 1/2W	
R9	0687-1231	R:FXD COMP 12K OHM 10% 1/2W	
R10		NOT ASSIGNED	
R11	0687-2211	R:FXD COMP 220 OHM 10% 1/2W	
R12	THRU		
R14		NOT ASSIGNED	
R15	0687-1011	R:FXD COMP 100 OHM 10% 1/2W	
R16		NOT SEPARATELY REPLACEABLE PART OF A7	
R17	0686-4335	R:FXD COMP 43K OHM 5% 1/2W	
R18		NOT SEPARATELY REPLACEABLE PART OF A7	
R19	0686-6825	R:FXD COMP 6800 OHM 5% 1/2W	
R20	0686-4735	R:FXD COMP 47K OHM 5% 1/2W	
R21	0686-5115	R:FXD COMP 510 OHM 5% 1/2W	
R22	AND		
R23		NOT ASSIGNED	
R24	0687-6801	R:FXD COMP 68 OHM 10% 1/2W	
R25	0687-6811	R:FXD COMP 680 OHM 10% 1/2W	
R26	0764-0044	R:FXD MET FLM 8.2K OHM 5% 2W	

See introduction to this section

Table 6-1. Reference Designation Index (Cont'd)

Circuit Reference	⊕ Stock No.	Description	Note
R27	0727-0314	R:FXD DEPC 90.9K OHM 1% 1/2W	
R28	0687-6801	R:FXD COMP 68 OHM 10% 1/2W	
R29	0727-0224	R:FXD DEPC 249K OHM 1% 1/2W	
R30	0767-0004	R:FXD MET FLN 5K OHM 5% 3W	
R31	0693-5621	R:FXD COMP 5600 OHM 10% 2W	
R32	0687-6801	R:FXD COMP 68 OHM 10% 1/2W	
R33	0693-3321	R:FXD COMP 3300 OHM 10% 2W	
R34	0687-6801	R:FXD COMP 68 OHM 10% 1/2W	
R35	0727-0100	R:FXD DEPC 1000 OHM 1% 1/2W	
R36	0727-0465	R:FXD DEPC 22.1K OHM 1% 1/2W	
R37	0687-2211	R:FXD COMP 220 OHM 10% 1/2W	
R38	0727-0208	R:FXD DEPC 100K OHM 1% 1/2W	
R39	0727-0208	R:FXD DEPC 100K OHM 1% 1/2W	
R40	0693-1231	R:FXD COMP 12K OHM 10% 2W	
R41	0687-6801	R:FXD COMP 68 OHM 10% 1/2W	
R42	0687-4731	R:FXD COMP 47K OHM 10% 1/2W	
R43	0690-1541	R:FXD COMP 150K OHM 10% 1W	
R44	0687-6801	R:FXD COMP 68 OHM 10% 1/2W	
R45	0687-4731	R:FXD COMP 47K OHM 10% 1/2W	
R46	0687-6801	R:FXD COMP 68 OHM 10% 1/2W	
R47	0687-5631	R:FXD COMP 56K OHM 10% 1/2W	
R48	0687-4741	R:FXD COMP 470K OHM 10% 1/2W	
R49	0689-2035	R:FXD COMP 20K OHM 5% 1W	
R50		NOT ASSIGNED	
R51	0690-2231	R:FXD COMP 22K OHM 10% 1W	
R52	0690-1031	R:FXD COMP 10K OHM 10% 1W	
R53		NOT SEPARATELY REPLACEABLE PART OF A8	
R54	0687-6801	R:FXD COMP 68 OHM 10% 1/2W	
R55	0687-6801	R:FXD COMP 68 OHM 10% 1/2W	
R56	0693-1531	R:FXD COMP 15K OHM 10% 2W	
R57	0687-6801	R:FXD COMP 68 OHM 10% 1/2W	
R58	0686-2035	R:FXD COMP 20K OHM 5% 1/2W	
R59		NOT SEPARATELY REPLACEABLE PART OF S1	
R60		NOT SEPARATELY REPLACEABLE PART OF A7	
R61	0687-3331	R:FXD COMP 33K OHM 10% 1/2W	
R62	0757-0092	R:FXD MET FLN 33K OHM 2% 1/2W	
R63		NOT SEPARATELY REPLACEABLE PART OF A8	
R64	2100-0398	R:VAR WW 50K OHM 3% LIN 5W	
R65	0687-6801	R:FXD COMP 68 OHM 10% 1/2W	
R66	0687-6801	R:FXD COMP 68 OHM 10% 1/2W	
R67		NOT SEPARATELY REPLACEABLE PART OF A8	
R68	AND		
R69		NOT ASSIGNED	
R70	0687-1541	R:FXD COMP 150K OHM 10% 1/2W	
R71	0687-1031	R:FXD COMP 10K OHM 10% 1/2W	
R72	0687-1021	R:FXD COMP 1000 OHM 10% 1/2W	
R73	0687-5601	R:FXD COMP 56 OHM 10% 1/2W	
R74		NOT ASSIGNED	
R75	0687-1051	R:FXD COMP 1 M OHM 10% 1/2W	
R76	0684-1041	R:FXD COMP 100K OHM 10% 1/4W	

See introduction to this section

Table 6-1. Reference Designation Index (Cont'd)

Circuit Reference	Stock No.	Description	Note
R77	0686-2425	R:FXD COMP 2400 OHM 5% 1/2W	
R78	0687-2741	R:FXD COMP 270K OHM 10% 1/2W	
R79	0686-6825	R:FXD COMP 6800 OHM 5% 1/2W	
R80	0686-1835	R:FXD COMP 18K OHM 5% 1/2W	
R81	0687-6801	R:FXD COMP 68 OHM 10% 1/2W	
R82	0687-4741	R:FXD COMP 470K OHM 10% 1/2W	
R83	0687-5601	R:FXD COMP 56 OHM 10% 1/2W	
R84	0687-1031	R:FXD COMP 10K OHM 10% 1/2W	
R85	0686-1025	R:FXD COMP 1000 OHM 5% 1/2W	
R86	0686-1025	R:FXD COMP 1000 OHM 5% 1/2W	
R87	0687-1061	R:FXD COMP 10 MEGOHM 10% 1/2W	
R88	0767-0010	R:FXD MET FLM 15K OHM 5% 3W	
R89		NOT SEPARATELY REPLACEABLE PART OF A5	
R90		NOT SEPARATELY REPLACEABLE PART OF A5	
R91		NOT SEPARATELY REPLACEABLE PART OF A5	
R92		NOT SEPARATELY REPLACEABLE PART OF A5	
R93	0730-0138	R:FXD DEPC 9 MEGOHM 1% 1W	
R94	0730-0157	R:FXD DEPC 4.5 MEGOHM 1% 1W	
R95	0727-0311	R:FXD DEPC 1.8 MEGOHM 1% 1/2W	
R96	0757-0187	R:FXD MET FLM 900K OHM 0.1% 1/2W	
R97	0757-0189	R:FXD MET FLM 450K OHM 0.1% 1/2W	
R98	0757-0188	R:FXD MET FLM 180K OHM 0.1% 1/2W	
R99	THRU		
R109	0687-5601	R:FXD COMP 56 OHM 10% 1/2W	
S1	3100-0387	SWITCH:ROTARY 1SECTION 4 POSITION (INCLUDES R59/S3)	
S2		NOT SEPARATELY REPLACEABLE PART OF A3	
S3		NOT SEPARATELY REPLACEABLE PART OF S1	
S4		NOT SEPARATELY REPLACEABLE PART OF A6	
S5	3101-0032	SWITCH:SLIDE 4PDT	
S6		NOT SEPARATELY REPLACEABLE PART OF A6	
S7	3101-0044	SWITCH:PUSHBUTTON SPST N/O	
T1	1781B-60A	TRANSFORMER:PULSE	
V1	5080-0424	ELECTRON TUBE:AGED	
V2	1932-0022	ELECTRON TUBE:DUAL TRIODE 6DJ8	
V3	1932-0022	ELECTRON TUBE:DUAL TRIODE 6DJ8	
V4	2140-0018	LAMP:GLOW 1/10W	
V5	1932-0022	ELECTRON TUBE:DUAL TRIODE 6DJ8	
V6	1932-0022	ELECTRON TUBE:DUAL TRIODE 6DJ8	
V7	1923-0051	ELECTRON TUBE: 12AU6	
V8	2140-0085	LAMP:NEON	
V9	2140-0085	LAMP:NEON	
V10	2140-0018	LAMP:GLOW 1/10W	
V11	1932-0022	ELECTRON TUBE:DUAL TRIODE 6DJ8	
V12	2140-0008	LAMP:GLOW,NE-2 NEON	
V13		NOT ASSIGNED	
V14	1932-0022	ELECTRON TUBE:DUAL TRIODE 6DJ8	
V15	1932-0022	ELECTRON TUBE:DUAL TRIODE 6DJ8	
XV1	THRU		
XV6	1200-0062	SOCKET:TUBE 9 PIN	
XV7	1200-0053	SOCKET:TUBE 7 PIN	
XV8	THRU		
XV10		NOT ASSIGNED	

* See introduction to this section

Table 6-1. Reference Designation Index (Cont'd)

Circuit Reference	⊕ Stock No.	Description	Note
XV11 XV12 AND XV13 XV14 XV15	1200-0062 1200-0062 1200-0062	SOCKET:TUBE 9 PIN NOT ASSIGNED SOCKET:TUBE 9 PIN SOCKET:TUBE 9 PIN	
	0370-0113 0370-0114 0370-0115 0370-0119 0370-0120 1140-0002	MISCELLANEOUS KNOB:TRIGGER SOURCE,DELAY SWEEP TIME KNOB:SWEEP MODE KNOB:SWEEP SELECTOR KNOB:TRIGGER SLOPE KNOB:TRIGGER LEVEL DIAL:10 TURN	

* See introduction to this section

Table 6-2. Replaceable Parts

Stock No.	Description #	Mfr.	Mfr. Part No.	TQ	RS
0130-0001	C: VAR CER 7-45 PF 500VDCW	28480	0130-0001	1	
0140-0006	C: FXD MICA 82 PF 10% 500VDCW	28480	0140-0006	1	
0140-0014	C: FXD MICA 56 PF 10% 500VDCW	00853	TYPE DR1456 B10	1	
0140-0018	C: FXD MICA 1000 PF 5% NPO 500VDCW	28480	0140-0018	1	
0140-0040	C: FXD MICA 75 PF 5%	00853	RCM15E750J	1	
0140-0044	C: FXD MICA 560 PF 10% NPO 500VDCW	28480	0140-0044	2	
0140-0092	C: FXD MICA 240 PF 5% 500VDCW	00853	TYPE DR1324 E5	1	
0140-0100	C: FXD MICA 33 PF 5% 500VDCW	00853	CM15E 330J	1	
0140-0101	C: FXD MICA 15 PF 5% 500VDCW	00853	RCM15C 150J	1	
0150-0012	C: FXD CER 0.01 UF 20% 1000VDCW	56289	H 1038	5	
0150-0052	C: FXD CER 0.05 UF 20% 400VDCW	56289	33C17A	3	
0150-0069	C: FXD CER 1000 PF +100-20% 500VDCW	72982	801010X5G0102Z	2	
0150-0070	C: FXD CER .02 UF 20% 500VDCW	72982	821011X5U0203M	11	
0160-0314	C: FXD MY 0.01 UF 5% 400VDCW	01281	TYPE 663UW	1	
0160-2103	C: FXD CER 2000 PF 20% 1000VDCW	91418	TYPE JF .002PF 20%	3	
0170-0018	C: FXD MY 1 UF 5% 200VDCW	84411	HEW 4	1	
0170-0019	C: FXD MY 0.1 UF 5% 200VDCW	28480	0170-0019	1	
0170-0021	C: FXD MY 4700 PF 10% 400VDCW	84411	TYPE 620S	1	
0170-0060	C: FXD MY 0.047 UF 10% 400VDCW	84411	TYPE 663 UW	1	
0180-0089	C: FXD ELECT 10 UF +100-10% 150VDCW	56289	30D106G150DF4	3	
0370-0113	KNOB:TRIGGER SOURCE,DELAY SWEEP TIME	28480	0370-0113	1	
0370-0114	KNOB:SWEEP MODE	28480	0370-0114	1	
0370-0115	KNOB:SWEEP SELECTOR	28480	0370-0115	1	
0370-0119	KNOB:TRIGGER SLOPE	28480	0370-0119	1	
0370-0120	KNOB:TRIGGER LEVEL	28480	0370-0120	1	
0684-1041	R:FXD COMP 100K OHM 10% 1/4W	01121	CB 1041	1	
0684-4741	R:FXD COMP 470K OHM 10% 1/4W	01121	CB 4741	1	
0686-1025	R:FXD COMP 1000 OHM 5% 1/2W	01121	EB 1025	2	
0686-1835	R:FXD COMP 18K OHM 5% 1/2W	01121	EB 1835	1	
0686-2035	R:FXD COMP 20K OHM 5% 1/2W	01121	EB 2035	1	
0686-2425	R:FXD COMP 2400 OHM 5% 1/2W	01121	EB 2425	1	
0686-4335	R:FXD COMP 43K OHM 5% 1/2W	01121	EB 4335	1	
0686-4735	R:FXD COMP 47K OHM 5% 1/2W	01121	EB 4735	1	
0686-5115	R:FXD COMP 510 OHM 5% 1/2W	01121	EB 5115	1	
0686-5635	R:FXD COMP 56K OHM 5% 1/2W	01121	EB 5635	1	
0686-6825	R:FXD COMP 6800 OHM 5% 1/2W	01121	EB 6825	2	
0687-1011	R:FXD COMP 100 OHM 10% 1/2W	01121	EB 1011	1	
0687-1021	R:FXD COMP 1000 OHM 10% 1/2W	01121	EB 1021	1	
0687-1031	R:FXD COMP 10K OHM 10% 1/2W	01121	EB 1031	2	
0687-1041	R:FXD COMP 100K OHM 10% 1/2W	01121	EB 1041	1	
0687-1051	R:FXD COMP 1 MEGOHM 10% 1/2W	01121	EB 1051	2	
0687-1061	R:FXD COMP 10 MEGOHM 10% 1/2W	01121	EB 1061	1	
0687-1231	R:FXD COMP 12K OHM 10% 1/2W	01121	EB 1231	1	
0687-1541	R:FXD COMP 150K OHM 10% 1/2W	01121	EB 1541	1	
0687-2211	R:FXD COMP 220 OHM 10% 1/2W	01121	EB 2211	3	
0687-2741	R:FXD COMP 270K OHM 10% 1/2W	01121	EB 2741	1	
0687-3331	R:FXD COMP 33K OHM 10% 1/2W	01121	EB 3331	1	
0687-4731	R:FXD COMP 47K OHM 10% 1/2W	01121	EB 4731	2	
0687-4741	R:FXD COMP 470K OHM 10% 1/2W	01121	EB 4741	3	
0687-5601	R:FXD COMP 56 OHM 10% 1/2W	01121	EB 5601	13	

See introduction to this section

Table 6-2. Replaceable Parts (Cont'd)

Stock No.	Description #	Mfr.	Mfr. Part No.	TQ	RS
0687-5631	R:FXD COMP 56K OHM 10% 1/2W	01121	EB 5631	1	
0687-6801	R:FXD COMP 68 OHM 10% 1/2W	01121	EB 6801	13	
0687-6811	R:FXD COMP 680 OHM 10% 1/2W	01121	EB 6811	1	
0689-2035	R:FXD COMP 20K OHM 5% 1W	01121	GB 2035	1	
0690-1031	R:FXD COMP 10K OHM 10% 1W	01121	GB 1031	1	
0690-1541	R:FXD COMP 150K OHM 10% 1W	01121	GB 1541	1	
0690-2231	R:FXD COMP 22K OHM 10% 1W	01121	GB 2231	1	
0693-1231	R:FXD COMP 12K OHM 10% 2W	01121	HB 1231	1	
0693-1531	R:FXD COMP 15K OHM 10% 2W	01121	HB 1531	1	
0693-3321	R:FXD COMP 3300 OHM 10% 2W	01121	HB 3321	1	
0693-5621	R:FXD COMP 5600 OHM 10% 2W	01121	HB 5621	1	
0727-0100	R:FXD DEPC 1000 OHM 1% 1/2W	19701	CD 1/2CR5	1	
0727-0208	R:FXD DEPC 100K OHM 1% 1/2W	19701	DC 1/2CR5	2	
0727-0224	R:FXD DEPC 249K OHM 1% 1/2W	19701	CF 1/2	1	
0727-0311	R:FXD DEPC 1.8 MEGOHM 1% 1/2W	19701	CF 1/2	1	
0727-0314	R:FXD DEPC 90.9K OHM 1% 1/2W	19701	CF 1/2	1	
0727-0465	R:FXD DEPC 22.1K OHM 1% 1/2W	19701	DC 1/2CR5	1	
0730-0138	R:FXD DEPC 9.0 MEGOHM 1% 1W	19701	DC 1R5	1	
0730-0157	R:FXD DEPC 4.5 MEGOHM 1% 1W	19701	DC 1R5	1	
0757-0092	R:FXD MET FLM 33K OHM 2% 1/2W	07115	C20	1	
0757-0187	R:FXD MET FLM 900K OHM 0.1% 1/2W	19701	MF7C-T-O	1	
0757-0188	R:FXD MET FLM 180K OHM 0.1% 1/2W	19701	MF7C-T-O	1	
0757-0189	R:FXD MET FLM 450K OHM 0.1% 1/2W	19701	MF7C-T-O	1	
0764-0044	R:FXD MET FLM 8.2K OHM 5% 2W	28480	0764-0044	1	
0767-0004	R:FXD MET FLM 5K OHM 5% 3W	07115	LPI	1	
0767-0010	R:FXD MET FLM 15K OHM 5% 3W	07115	LPI-3	1	
1140-0002	DIAL:10 TURN	73490	MODEL RB DUO-DIAL	1	
1200-0053	SOCKET:TUBE 7 PIN	71785	11151-11	1	
1200-0062	SOCKET:TUBE 9 PIN	71785	121 5111060	8	
1250-0083	CONNECTOR:BNC	28480	1250-0083	2	
1251-0136	CONNECTOR:MALE 32 PIN	02660	264 10032P	1	
1450-0116	LAMP:NEON	28480	1450-0116	1	
1781B-19A	ASSY:SWEEP TIME & SWEEP SELECTOR SWITCH	28480	1781B-19A	1	
1781B-19B	ASSY:TRIGGER SOURCE SWITCH	28480	1781B-19B	1	
1781B-19C	ASSY:TRIGGER SLOPE SWITCH	28480	1781B-19C	1	
1781B-60A	TRANSFORMER:PULSE	28480	1781B-60A	1	
1781B-65A	ASSY:DELAYING SWEEP & TRIGGER BOARD	28480	1781B-65A	1	
1781B-65B	ASSY:SWEEP TIME SWITCH BOARD	28480	1781B-65B	1	
1850-0062	TRANSISTOR:SPECIAL	28480	1850-0062	1	
1850-0091	TRANSISTOR:GERMANIUM PNP 2N2048	87216	2N2048	1	
1850-0092	TRANSISTOR:PNP 2N2043	04713	2N2043	1	
1851-0017	TRANSISTOR:2N1304	01295	2N1304	1	
1901-0040	SEMICON DEVICE:DIODE SILICON	07263	FDG 1088	2	
1901-0096	SEMICON DEVICE:DIODE SILICON	28480	1901-0096	1	
1901-0439	SEMICON DEVICE:DIODE SILICON	28480	1901-0439	1	
1902-0034	SEMICON DEVICE:DIODE BREAKDOWN	28480	1902-0034	1	
1912-0007	SEMICON DEVICE:DIODE TUNNEL 1N3714	03508	1N3714	2	
1923-0007	ELECTRON TUBE:PENTODE 12AU6	33173	12AU6	1	
1932-0022	ELECTRON TUBE:DUAL TRIODE 6DJ8	73445	6DJ8	7	
2100-0398	R:VAR WW 50K OHM 3% LIN 5W	28480	2100-0398	1	
2100-0404	R:VAR COMP 50K-50K-100 OHM 30% 1/4W	28480	2100-0404	1	

See introduction to this section

Table 6-2. Replaceable Parts (Cont'd)

Stock No.	Description #	Mfr.	Mfr. Part No.	TQ	RS
2100-0406	R:VAR COMP4X 5K OHM 30% 1/4W	28480	2100-0406	1	
2100-0899	R:VAR COMP10K-5K-25K OHM 20% 1/4W	28480	2100-0899	1	
2140-0008	LAMP:GLOW NE-2 NEON	24455	NE2	1	
2140-0018	LAMP:GLOW 1/10W	24455	NE 2E1	2	
2140-0085	LAMP:NEON	74276	A093	2	
3100-0387	SWITCH:ROTARY 1 SECTION 4 POSITION INCLUDES R59/S3	28480	3100-0387	1	
3101-0032	SWITCH:SLIDE 4PDT	42190	6613M	1	
3101-0044	SWITCH:PUSHBUTTON SEST N/O	81073	39-1 N.O.	1	
5080-0424	ELECTRON TUBE:AGED	28480	5080-0424	1	
9140-0107	COIL:FXD RF 27 UH	28480	9140-0107	1	
9140-0121	COIL:FXD 1.8 UH	28480	9140-0121	2	

See introduction to this section

TABLE 6-3. CODE LIST OF MANUFACTURERS

The following code numbers are from the Federal Supply Code for Manufacturers Cataloging Handbooks H4-1 (Name to Code) and H4-2 (Code to Name) and their latest supplements. The date of revision and the date of the supplements used appear at the bottom of each page. Alphabetical codes have been arbitrarily assigned to suppliers not appearing in the H4 handbooks.

Code No.	Manufacturer	Address	Code No.	Manufacturer	Address	Code No.	Manufacturer	Address	Code No.	Manufacturer	Address
00000	U. S. A. Common	Any supplier of U.S.	07263	Fairchild Semiconductor Corp.	Mountain View, Calif.	63743	Ward Leonard Electric	ML Vernon, N.Y.	74861	Industrial Condenser Corp.	Chicago, Ill.
00136	McCoy Electronics	Mount Holly Springs, Pa.	07322	Minnesota Rubber Co.	Minneapolis, Minn.	54294	Shalorosa Mfg. Co.	Selma, N. C.	74868	R. F. Products Division of Amphol-	
00334	Humidil Co.	Colton, Calif.	07700	Technical Wire Products	Springfield, N.J.	55825	Singon Electric Co.	Chicago, Ill.		Berg Electronics Corp.	Danbury, Conn.
00335	Westrex Corp.	New York, N.Y.	07916	Continental Device Corp.	Hawthorne, Calif.	55333	Sonotone Corp.	Elmsford, N.Y.	74970	E. F. Johnson Co.	Wasson, Minn.
00373	Garlock Packing Co., Electronic Products Div.	Camden, N.J.	07933	Rheem Semiconductor Corp.	Bloomfield View, Calif.	55538	Sorenson & Co., Inc.	So. Norwalk, Conn.	75942	International Resistance Co.	Philadelphia, Pa.
00556	Aerovox Corp.	New Bedford, Mass.	07966	Shockey Semi-Conductor Laboratories	Palo Alto, Calif.	56137	Sprague Fibre Co., Inc.	Tonawanda, N.Y.	75173	Jones, Howard B., Division of Cinch Mfg. Corp.	Chicago, Ill.
00779	Amp, Inc.	Harrisburg, Pa.	07980	Boonton Radio Corp.	Boonton, N.J.	59446	Talon, Inc.	St. Paul, Minn.	75378	Jones Knights Co.	Sanford, Ill.
00781	Aircraft Radio Corp.	Boonton, N.J.	08145	U.S. Engineering Co.	Los Angeles, Calif.	59730	Thomas & Betts Co.	Elizabeth 1, N. J.	75382	Kelka Electric Corporation	Mt. Vernon, N.Y.
00815	Northern Engineering Laboratories, Inc.	Burlington, Wis.	08358	Burgess Battery Co.	Niagara Falls, Ontario, Canada	60741	Tripplett Electrical Inc.	Shuffton, Ohio	75878	Levz Electric Mfg. Co.	Chicago, Ill.
00853	Sangamo Electric Company, Ordill Division (Capacitors)	Marion, Ill.	08717	Stoan Company	Durban, Calif.	61775	Union Switch and Signal, Div. of Westinghouse Air Brake Co.	Swissvale, Pa.	75915	L.H. Little Inc.	Des Plaines, Ill.
00856	Go Engineering Co.	Los Angeles, Calif.	08718	Cannon Electric Co., Phoenix Div.	Phoenix, Ariz.	62119	Universal Electric Co.	Owosso, Mich.	75986	Ludwig Mfg. Co.	Erie, Pa.
00891	Carl E. Holmes Corp.	Los Angeles, Calif.	08792	CBS Electronics Semiconductor Operations, Div. of C. B. S., Inc.	Lowell, Mass.	63743	Wood-Leonard Electric Co.	Mt. Vernon, N.Y.	76219	C. W. Marwede	San Francisco, Calif.
01121	Allen Bradley Co.	Milwaukee, Wis.	08984	Mel-Rain	Indianapolis, Ind.	64959	Western Electric Co., Inc.	New York, N.Y.	76433	Wicanoid Electronic Mfg. Corp.	Brooklyn, N.Y.
01255	Liton Industries, Inc.	Beverly Hills, Calif.	09026	Subcock Relays, Inc.	Costa Mesa, Calif.	65992	Western Inst. Div. of Daystrom, Inc.	Newark, N.J.	76487	James Millen Mfg. Co., Inc.	Malden, Mass.
01281	Pacific Semiconductor, Inc.	Colver City, Calif.	09134	Texas Capacitor Co.	Houston, Texas	66295	Whitt Manufacturing Co.	Chicago 23, Ill.	76489	J. W. Miller Co.	Los Angeles, Calif.
01295	Texas Instruments, Inc. Transistor Products Div.	Dallas, Texas	09250	Electro Assemblies, Inc.	Chicago, Ill.	66346	Wollensak Optical Co.	Rechester, N.Y.	76580	Woodstock Mills	San Leandro, Calif.
01349	The Alliance Mfg. Co.	Alliance, Ohio	09569	Mallory Battery Co. of Canada, Ltd.	Toronto, Ontario, Canada	78276	Allen Mfg. Co.	Hartford, Conn.	76585	Huiler Electric Co.	San Cleveland, Ohio
01561	Chassi-Trak Corp.	Indianapolis, Ind.	09569	The Bristol Co.	Waterbury, Conn.	70399	Allied Control Co., Inc.	New York, N.Y.	76854	Oak Manufacturing Co.	Crystal Lake, Ill.
01589	Pacific Relays, Inc.	Van Nuys, Calif.	10214	General Transistor Western Corp.	Los Angeles, Calif.	70319	Altimet Screw Prod. Co., Inc.	Garson City, N.Y.	77068	Bendix Pacific Division of Bendix Corp.	Mo. Hollywood, Calif.
01930	Aeromerk Corp.	Rockford, Ill.	10411	Ti-Tal, Inc.	Benajay, Calif.	70485	Atlantic India Rubber Works, Inc.	Chicago, Ill.	77075	Pacific Metals Co.	San Francisco, Calif.
01961	Pulax Engineering Co.	Santa Clara, Calif.	10646	Carborundum Co.	Niagara Falls, N.Y.	70563	Asperite Co., Inc.	New York, N.Y.	77221	Phasikon Instrument and Electronic Co.	South Pasadena, Calif.
02314	Ferroxube Corp. of America	Saugerties, N.Y.	11236	CTS of Berne, Inc.	Berne, Ind.	70903	Belden Mfg. Co.	Chicago, Ill.	77258	Phell Mfg. Co.	Chicago, Ill.
02286	Cole Mfg. Co.	Palo Alto, Calif.	11237	Chicago Telephone of California, Inc.	So. Pasadena, Calif.	70998	Bird Electronic Corp.	Cleveland, Ohio	77252	Philadelphia Steel and Wire Corp.	Philadelphia, Pa.
02660	Amp' enol-Borg Electronics Corp.	Chicago, Ill.	11312	Microwave Electronics Corp.	Palo Alto, Calif.	71002	Birchback Radio Co.	New York, N.Y.	77342	Peltar and Bromfield, Div. of American Machine and Foundry	Princeton, Ind.
02735	Radio Corp. of America, Semiconductor and Materials Div.	Somerville, N.J.	11534	Duncan Electronic, Inc.	Santa Ana, Calif.	71041	Boston Gear Works Div. of Murray Co. of Texas	Quincy, Mass.	77620	Radio Condenser Co.	Camden, N. J.
02771	Vocaline Co. of America, Inc.	Old Saybrook, Conn.	11711	General Instrument Corporation Semiconductor Division	Newark, N.J.	71286	Camloc Fastener Corp.	Cleveland, Ohio	77638	Radio Receptor Co., Inc.	Brooklyn, N.Y.
02777	Hopkins Engineering Co.	San Fernando, Calif.	11717	Imperial Electronic, Inc.	Buena Park, Calif.	71313	Allen D. Cardwell Electronic Prod. Corp.	Plainville, Conn.	77764	Resistance Products Co.	Harrisburg, Pa.
03508	G. E. Semiconductor Products Dept.	Syracuse, N.Y.	11870	Melabco, Inc.	Palo Alto, Calif.	71400	Bussmann Fuse Div. of McGraw- Edison Co.	St. Louis, Mo.	78189	Shaleproof Division of Illinois Tool Works	Elgin, Ill.
03705	Apex Machine & Tool Co.	Dayton, Ohio	12597	Clarestal Mfg. Co.	Dover, N. H.	71436	Chicago Condenser Corp.	Chicago, Ill.	78283	Signal Indicator Corp.	New York, N.Y.
03797	Eldema Corp.	El Monte, Calif.	12859	Nugpon Electric Co., Ltd.	Tokyo, Japan	71450	CTS Corp.	Elkhart, Ind.	78290	Sinithars-Dunn Inc.	Pittman, N. J.
03877	Transiron Electronic Corp.	Wakefield, Mass.	12930	Delta Semiconductor Inc.	Newport Beach, Calif.	71468	Cannon Electric Co.	Los Angeles, Calif.	78452	Thompson-Bremar & Co.	Chicago, Ill.
03888	Pyrofilm Resistor Co.	Morristown, N.Y.	13103	Thermolloy	Dallas, Texas	71471	Cinema Engineering Co.	Burbank, Calif.	78471	Tilley Mfg. Co.	San Francisco, Calif.
03954	Air Marine Motors, Inc.	Los Angeles, Calif.	13396	Te-lektron (G. M. B. N.)	Hanover, Germany	71482	C. P. Clark & Co.	Chicago, Ill.	78486	Stachpole Carbon Co.	St. Marys, Pa.
04009	Arrow, Hart and Hegeman Elect. Co.	Hartford, Conn.	14099	Sam-Tech	Newbury Park, Calif.	71590	Centralist Div. of Globe Union Inc.	Chicago, Ill.	78493	Standard Thomsen Corp.	Weston, Ohio
04062	Elenco Products Co.	New York, N.Y.	14193	Calif. Resistor Corp.	San Jose, Calif.	71700	The Cornish Wire Co.	New York, N.Y.	78553	Timmermans Products, Inc.	Cleveland, Ohio
04222	H-Q Division of Aerovox	Myrtle Beach, S. C.	14298	American Components, Inc.	Coshocton, N.J.	71744	Chicago Miniature Lamp Works	Chicago, Ill.	78790	Transformer Engineers	Pasadena, Calif.
04238	Elgen National Watch Co., Electronics Division	Burbank, Calif.	14655	Cornell Dlubaker Elec. Corp.	So. Plainfield, N.J.	71753	A. O. Smith Corp., Crowley Div.	Chicago, Ill.	78847	Ucklin Co.	Newtown, Mass.
04404	Dymec Division of Hewlett-Packard Co.	Palo Alto, Calif.	15909	The Daven Co.	Livingston, N.J.	71785	Cinch Mfg. Corp.	Chicago, Ill.	79142	Vander Root, Inc.	Hartford, Conn.
04651	Sylvania Electric Prods., Inc. Electronic Tube Div.	Mountain View, Calif.	16588	De Jur-Ansco Corporation	Long Island City 1, N.Y.	71984	Dow Corning Corp.	Midland, Mich.	79251	Wenco Mfg. Co.	Chicago, Ill.
04713	Motorola, Inc., Semiconductor Prod. Div.	Phoenix, Arizona	16758	Delco Radio Div. of G. M. Corp.	Kokomo, Ind.	72092	Eitel-McCullough, Inc.	San Bruno, Calif.	79727	Continental-Wint Electronics Corp.	Philadelphia, Pa.
04732	Filtrol Co., Inc., Western Div.	Culver City, Calif.	18873	E. I. DuPont and Co., Inc.	Wilmington, Del.	72136	Electro Motive Mfg. Co., Inc.	Willimaetic, Conn.	79963	Zierick Mfg. Corp.	New Rochelle, N.Y.
04773	Automatic Electric Co.	Northlake, Ill.	19315	Eclipse Pioneer, Div. of Bendix Aviation Corp.	Teterboro, N.J.	71707	Coto Coil Co., Inc.	Providence, R.I.	80021	Mepco Division of Sessions Clock Co.	Morristown, N.J.
04777	Automatic Electric Sales Corp.	Northlake, Ill.	19500	Thomas A. Edison Industries, Div. of McGraw-Edison Co.	West Orange, N.J.	72354	E. East & Co.	Chicago, Ill.	80020	Scheltzer Alloy Products	Elizabeth, N.J.
04796	Sequoia Wire & Cable Co.	Redwood City, Calif.	19701	Electra Manufacturing Co.	Kansas City, Mo.	72619	Dialight Corp.	Brooklyn, N.Y.	80130	Times Facsimile Corp.	New York, N.Y.
04870	P. M. Motor Company	Chicago 44, Ill.	20183	Electronic Tube Corp.	Philadelphia, Pa.	72656	General Ceramics Corp.	Kossboy, N.J.	80131	Electronic Industries Association, Any brand tube meeting EIA standards	Washington, D. C.
05006	Twentieth Century Plastics, Inc.	Los Angeles, Calif.	21226	Executive, Inc.	New York, N.Y.	72699	General Instrument Corp., Semiconductor Div.	Newark, N.J.	80207	Unimax Switch, Div. of W. L. Masson Corp.	Wallingford, Conn.
05277	Westinghouse Electric Corp., Semi-Conductor Dept.	Youngwood, Pa.	21520	Fansteel Metallurgical Corp.	No. Chicago, Ill.	72756	Girard-Hepkins	Oakland, Calif.	80223	United Transformer Corp.	New York, N.Y.
05347	Ultratron, Inc.	San Mateo, Calif.	21525	Fed. Telephone and Radio Corp.	New Britain, Conn.	72765	Drake Mfg. Co.	Chicago, Ill.	80248	Outford Electric Corp.	Chicago, Ill.
05593	Illuminotron Engineering Co.	Saneyvale, Calif.	24446	General Electric Co.	Schenectady, N.Y.	72825	Hugh H. Eby Inc.	Philadelphia, Pa.	80294	Bowens Laboratories, Inc.	Riverside, Calif.
05624	Barber Colman Co.	Rockford, Ill.	24455	G. E., Lamp Division	Nela Park, Cleveland, Ohio	72928	Godeman Co.	Chicago, Ill.	80411	Acro Div. of Rohlfshaw Fulton Controls Co.	Columbus 16, Ohio
05728	Tiffen Optical Co.	Roslyn Heights, Long Island, N.Y.	24655	General Radio Co.	West Concord, Mass.	72964	Robert M. Hadley Co.	Los Angeles, Calif.	80486	All Star Products Inc.	Defiance, Ohio
05729	Metropolitan Telecommunications Corp., Metro Cap. Division	Brooklyn, N.Y.	26365	Gries Reproducer Corp.	New Rochelle, N.Y.	72982	Erle Resistor Corp.	Erie, Pa.	80583	Hammerlund Co., Inc.	New York, N.Y.
05783	Stewart Engineering Co.	Santa Cruz, Calif.	26462	Globet File Co. of America, Inc.	Carlsbad, N.J.	73061	Hansen Mfg. Co., Inc.	Princeton, Ind.	80640	Stevens, Arnold, Co., Inc.	Boston, Mass.
06004	The Bassick Co.	Bridgeport, Conn.	26592	Hamilton Watch Co.	Lancaster, Pa.	73076	H. W. Harper Co.	Chicago, Ill.	81030	International Instruments, Inc.	New Haven, Conn.
06175	Bausch and Lomb Optical Co.	Rochester, N.Y.	28480	Hewlett-Packard Co.	Palo Alto, Calif.	73138	Helipot Div. of Beckman Instruments, Inc.	Fullerton, Calif.	81073	Grayhill Co.	LaGrange, Ill.
06402	E. T. A. Products Co. of America	Chicago, Ill.	31173	G. E. Receiving Tube Dept.	Owensboro, Ky.	73293	Hughes Products Division of Hughes Aircraft Co.	Newport Beach, Calif.	81095	Triad Transformer Corp.	Vanice, Calif.
06555	Beede Electrical Instrument Co., Inc.	Penacook, N.H.	35434	Lectrohn Inc.	Chicago, Ill.	73445	Amperex Electronic Co., Div. of North American Philips Co., Inc.	Hicksville, N.Y.	81212	Winchester Electronics Co., Inc.	Newark, Conn.
06751	U. S. Sencor Division of Nuclear Corp. of America	Phoenix, Arizona	37942	P. R. Malloy & Co., Inc.	Indianapolis, Ind.	73490	Beckman Helipot Corp.	So. Pasadena, Calif.	81349	Military Specification	
06812	Torrington Mfg. Co., West Div.	Van Nuys, Calif.	40920	Minitaire Precision Bearings, Inc.	Koene, N. H.	73506	Bradley Semiconductor Corp.	Hamden, Conn.	81415	Wilco Products, Inc.	Cleveland, Ohio
07115	Corning Glass Works Electronic Components Dept.	Bradford, Pa.	42190	Melter Co.	Chicago, Ill.	73506	Bradley Semiconductor Corp.	Hamden, Conn.	81483	International Rectifier Corp.	Newton, Mass.
07126	Digitran Co.	Pasadena, Calif.	43990	C. A. Morgan Co.	Englewood, Colo.	73559	Carling Electric, Inc.	Hartford, Conn.	81541	The Airpas Products Co.	El Segundo, Calif.
07137	Transistor Electronics Corp.	Minneapolis, Minn.	44655	Ohwite Mfg. Co.	Stokie, Ill.	73682	George K. Garrett Co., Inc.	Philadelphia, Pa.	81860	Berry Controls, Inc.	Cambridge, Mass.
07138	Westinghouse Electric Corp. Electronic Tube Div.	Elmira, N.Y.	47904	Polaroid Corp.	Cambridge, Mass.	73734	Federal Screw Prod. Co.	Chicago, Ill.	82042	Carier Parts Co.	Skokie, Ill.
07261	Avnet Corp.	Los Angeles, Calif.	48620	Precision Thermometer and Inst. Co.	Philadelphia, Pa.	73743	Fischer Special Mfg. Co.	Cincinnati, Ohio	82142	Jeffers Electronics Division of Speer Carbon Co.	De Bois, Pa.
			49956	Raytheon Company	Lexington, Mass.	73793	The General Industries Co.	San Jose, Calif.	82170	Allen B. DuMont Labs, Inc.	Clifton, N. J.
			52090	Rowan Controller Co.	Baltimore, Md.	73905	Jennings Radio Mfg. Co.	Winchester, Mass.			
						74455	J. H. Wines, and Sons				

Revised: Nov. 14, 1963
00015-34

F. S. C. Handbook Supplements
H4-1 Dated March 1963
H4-2 Dated March 1962

HEWLETT-PACKARD SALES AND SERVICE

UNITED STATES

ALABAMA

P.O. Box 4207
2003 Byrd Spring Road S.W.
Huntsville 35802
Tel: (205) 881-4591
TWX: 810-726-2284

ARIZONA

2336 E. Magnolia St.
Phoenix 85034
Tel: (602) 252-5061
TWX: 910-951-1330

5737 East Broadway
Tucson 85716
Tel: (602) 298-2313
TWX: 910-952-1162

CALIFORNIA

1430 East Orangethorpe Ave.
Fullerton 92631
Tel: (714) 870-1000

3939 Lankershim Boulevard
North Hollywood 91604
Tel: (213) 877-1282
TWX: 910-499-2170

1101 Embarcadero Road
Palo Alto 94303
Tel: (415) 327-6500
TWX: 910-373-1280

2220 Watt Ave.
Sacramento 95825
Tel: (916) 482-1463
TWX: 910-367-2092

9606 Aero Drive
San Diego 92123
Tel: (714) 279-3200
TWX: 910-335-2000

COLORADO

7965 East Prentice
Englewood 80110
Tel: (303) 771-3455
TWX: 910-935-0705

CONNECTICUT

508 Tolland Street
East Hartford 06108
Tel: (203) 289-9394
TWX: 710-425-3416

111 East Avenue
Norwalk 06851
Tel: (203) 853-1251
TWX: 710-468-3790

FLORIDA

P.O. Box 24210
2806 W. Oakland Park Blvd.
Ft. Lauderdale 33307
Tel: (305) 731-2020
TWX: 510-955-4099

P.O. Box 20007

Herdon Station 32814
621 Commonwealth Avenue
Orlando
Tel: (305) 841-3970
TWX: 810-850-0113

GEORGIA

P.O. Box 28234
450 Interstate North
Atlanta 30328
Tel: (404) 436-6181
TWX: 810-786-4890

ILLINOIS

5500 Howard Street
Skokie 60076
Tel: (312) 677-0400
TWX: 910-223-3613

INDIANA

3839 Meadows Drive
Indianapolis 46205
Tel: (317) 546-4891
TWX: 810-341-3263

LOUISIANA

P.O. Box 856
1942 Williams Boulevard
Kenner 70062
Tel: (504) 721-6201
TWX: 810-955-5524

MARYLAND

6707 Whitestone Road
Baltimore 21207
Tel: (301) 944-5400
TWX: 710-862-9157

P.O. Box 1648
2 Choke Cherry Road
Rockville 20850
Tel: (301) 948-6370
TWX: 710-828-9684

MASSACHUSETTS

32 Hartwell Ave.
Lexington 02173
Tel: (617) 861-8960
TWX: 710-326-6904

MICHIGAN

21840 West Nine Mile Road
Southfield 48075
Tel: (313) 353-9100
TWX: 810-224-4882

MINNESOTA

2459 University Avenue
St. Paul 55114
Tel: (612) 645-9461
TWX: 910-583-3734

MISSOURI

11131 Colorado Ave.
Kansas City 64137
Tel: (816) 763-8000
TWX: 910-771-2087

2812 South Brentwood Blvd.
St. Louis 63144
Tel: (314) 962-5000
TWX: 910-760-1670

NEW JERSEY

W. 120 Century Road
Paramus 07652
Tel: (201) 265-5000
TWX: 710-990-4951

1060 N. Kings Highway
Cherry Hill 08034
Tel: (609) 667-4000
TWX: 710-892-4945

NEW MEXICO

P.O. Box 8366
Station C
6501 Lomas Boulevard N.E.
Albuquerque 87106
Tel: (505) 265-3719
TWX: 910-969-1665

156 Wyatt Drive
Las Cruces 88001
Tel: (505) 526-2485
TWX: 910-983-0550

NEW YORK

1702 Central Avenue
Albany 12205
Tel: (518) 869-8462
TWX: 710-441-8270

1219 Campville Road
Endicott 13760
Tel: (607) 754-0050
TWX: 510-252-0890

82 Washington Street
Poughkeepsie 12601
Tel: (914) 454-7330
TWX: 510-248-C012

39 Saginaw Drive
Rochester 14623
Tel: (716) 473-9500
TWX: 510-253-5981

5858 East Molloy Road
Syracuse 13211
Tel: (315) 454-2486
TWX: 710-541-0482

1 Crossways Park West
Woodbury 11797
Tel: (516) 921-0300
TWX: 510-223-0811

NORTH CAROLINA

P.O. Box 5188
1923 North Main Street
High Point 27262
Tel: (919) 885-8101
TWX: 510-926-1516

OHIO

25575 Center Ridge Road
Cleveland 44145
Tel: (216) 835-0300
TWX: 810-427-9129

3460 South Dixie Drive
Dayton 45439
Tel: (513) 298-0351
TWX: 810-459-1925

1120 Morse Road
Columbus 43229
Tel: (614) 846-1300

OKLAHOMA

2919 United Founders Boulevard
Oklahoma City 73112
Tel: (405) 848-2801
TWX: 910-830-6862

OREGON

Westhills Mall, Suite 158
4475 S.W. Schoolls Ferry Road
Portland 97225
Tel: (503) 292-9171
TWX: 910-464-6103

PENNSYLVANIA

2500 Moss Side Boulevard
Monroeville 15146
Tel: (412) 271-0724
TWX: 710-797-3650

1021 8th Avenue
King of Prussia Industrial Park
King of Prussia 19406
Tel: (215) 265-7000
TWX: 510-660-2670

RHODE ISLAND

873 Waterman Ave.
East Providence 02914
Tel: (401) 434-5535
TWX: 710-381-7573

TEXAS

P.O. Box 1270
201 E. Arapaho Rd.
Richardson 75080
Tel: (214) 231-6101
TWX: 910-867-4723

P.O. Box 22813
6300 Westpark Drive
Suite 100
Houston 77027
Tel: (713) 781-6000
TWX: 910-881-2645

231 Billy Mitchell Road
San Antonio 78226
Tel: (512) 434-4171
TWX: 910-871-1170

UTAH

2890 South Main Street
Salt Lake City 84115
Tel: (801) 487-0715
TWX: 910-925-5681

VERMONT

P.O. Box 2287
Kennedy Drive
South Burlington 05401
Tel: (802) 658-4465
TWX: 510-299-0025

VIRGINIA

P.O. Box 6514
2111 Spencer Road
Richmond 23230
Tel: (703) 485-3431
TWX: 710-956-0157

WASHINGTON

433-108th N.E.
Bellevue 98004
Tel: (206) 454-3971
TWX: 910-443-2303

*WEST VIRGINIA

Charleston
Tel: (304) 768-1232

FOR U.S. AREAS NOT LISTED:

Contact the regional office nearest you: Atlanta, Georgia... North Hollywood, California... Paramus, New Jersey... Skokie, Illinois. Their complete addresses are listed above.

*Service Only

CANADA

ALBERTA

Hewlett-Packard (Canada) Ltd.
11745 Jasper Ave.
Edmonton
Tel: (403) 482-5561
TWX: 610-831-2431

BRITISH COLUMBIA

Hewlett-Packard (Canada) Ltd.
4519 Canada Way
North Burnaby 2
Tel: (604) 433-8213
TWX: 610-922-5059

MANITоба

Hewlett-Packard (Canada) Ltd.
511 Bradford Ct.
Winnipeg
Tel: (204) 786-7581
TWX: 610-971-3531

NOVA SCOTIA

Hewlett-Packard (Canada) Ltd.
2745 Dutch Village Rd.
Suite 206
Halifax
Tel: (902) 455-0511
TWX: 610-271-4482

ONTARIO

Hewlett-Packard (Canada) Ltd.
880 Lady Ellen Place
Ottawa 3
Tel: (613) 722-4223
TWX: 610-562-1952

Hewlett-Packard (Canada) Ltd.
50 Galaxy Blvd.
Rexdale
Tel: (416) 677-9611
TWX: 610-492-4246

QUEBEC

Hewlett-Packard (Canada) Ltd.
275 Hymus Boulevard
Pointe Claire
Tel: (514) 697-4232
TWX: 610-422-3022
Telex: 01-20607

FOR CANADIAN AREAS NOT LISTED:

Contact Hewlett-Packard (Canada) Ltd. in Pointe Claire, at the complete address listed above.

CENTRAL AND SOUTH AMERICA

ARGENTINA

Hewlett-Packard Argentina
S.A.C.e.I
Lavalle 1171 - 3°
Buenos Aires
Tel: 35-0436, 35-0627, 35-0431
Telex: 012-1009
Cable: HEWPACKARG

BRAZIL

Hewlett-Packard Do Brasil
I.e.C. Ltda.
Rua Frei Caneca 1119
Sao Paulo - 3, SP
Tel: 288-7111, 287-5858
Cable: HEWPACK Sao Paulo

Hewlett-Packard Do Brasil
Praca Dom Feliciano 78
Salas 806/808
Porto Alegre
Rio Grande do Sul (RS)-Brasil
Tel: 25-8470
Cable: HEWPACK Porto Alegre

Hewlett-Packard Do Brasil
I.e.C. Ltda.
Rua da Matriz 29
Botafogo ZC-02
Rio de Janeiro, GB
Tel: 246-4417
Cable: HEWPACK Rio de Janeiro

Hewlett-Packard Do Brasil

Industria e Comercio Ltda.
Praca Dom Feliciano 78
Salas 806-8
Porto Alegre RGS

CHILE

Héctor Calcagni y Cia, Ltda.
Bustos, 1932-3er Piso
Casilla 13942
Santiago
Tel: 423 96
Cable: CÁLCAGNI Santiago

COLOMBIA

Instrumentacion
Henrik A. Langebaek & Kier
Ltda.
Carrera 7 No. 48-89
Apartado Aereo 6287
Bogota, 1 D.E.
Tel: 45-78-06, 45-55-46
Cable: AARIS Bogota
Telex: 44400 INSTOD

COSTA RICA

Lic. Alfredo Gallegos Guardián
Apartado 10159
San José
Tel: 21-86-13
Cable: GALGUR San José

ECUADOR

Laboratorios de Radio-Ingenieria
Calle Guayaquil 1246
Post Office Box 3199
Quito
Tel: 212-496; 219-185
Cable: HORVATH Quito

EL SALVADOR

Electrónica
Apartado Postal 1589
Blvd. Venezuela 1231
San Salvador
Tel: 217527; 214895
Cable: ELECTRONICA
San Salvador

MEXICO

Hewlett-Packard Mexicana S. de C.V.
622 Adolfo Prieto
Col. del Valle
Mexico 12, D.F.
Tel: 543-4232; 523-1874
Telex: 0017-74507

NIGARASUA

Roberto Terán G.
Apartado Postal 689
Edificio Terán
Managua
Tel: 3451, 3452
Cable: ROTERAN Managua

PANAMA

Electrónico Balboa, S.A.
P.O. Box 4929
Ave. Manuel Espinosa No. 13-50
Bldg. Alina
Panama City
Tel: 230833
Telex: 3481003, Curundo,
Canal Zone
Cable: ELECTRON Panama City

PERU

Compañia Electro Medica S.A.
Ave. Enrique Canaval 312
San Isidro
Casilla 1030
Lima
Tel 22-3900
Cable: ELMED Lima

PUERTO RICO

San Juan Electronics, Inc.
P.O. Box 5167
Ponce de Leon 154
Pda. 3-PTA de Tierra
San Juan 00906
Tel: (809) 725-3342, 722-3342
Cable: SATRONICS San Juan
Telex: SATRON 3450 332

SURINAME

SurTel-Radio Holland N.V.
P.O. Box 155
Paramaribo
Tel: 72118
Cable: Treurniet Paramaribo

URUGUAY

Pablo Ferrando S.A.
Comercial e Industrial
Avenida Italia 2877
Casilla de Correo 370
Montevideo
Tel: 40-3102
Cable: RADIUM Montevideo

VENEZUELA

Hewlett-Packard De Venezuela
C.A.
Apartado 50933
Caracas
Tel: 71.88.05, 71.88.69, 71.99.30
Cable: HEWPACK Caracas
Telex: 39521146

FOR AREAS NOT LISTED,

CONTACT: Hewlett-Packard
INTERCONTINENTAL
3200 Hillview Ave.
Palo Alto, California 94304
Tel: (415) 493-1501
TWX: 910-373-1267
Cable: HEWPACK Palo Alto
Telex: 034-8461

EUROPE

AUSTRIA

Unilab GmbH
Wissenschaftliche Instrumente
Rummelhardtgasse 6
P.O. Box 33
A-1095 Vienna
Tel: (222) 42 61 81, 43 13 94
Cable: LABORINSTRUMENT
Vienna
Telex: 75 762

BELGIUM

Hewlett-Packard S.A. Benelux
348 Boulevard du Souverain
B-1160 Brussels
Tel: (02) 722240
Cable: PALOBEN Brussels
Telex: 23 494

DENMARK

Hewlett-Packard A/S
Datavej 38
DK-3450 Birkerød
Tel: (01) 81 66 40
Cable: HEWPACK AS
Telex: 66 40

Hewlett-Packard A/S
Torvet 9
DK-8600 Silkeborg
Tel: (06)-82-71-66

FINLAND

Hewlett-Packard Oy
Bulevardi 26
P.O. Box 12185
Helsinki 12
Tel: 13-730
Cable: HEWPACKOY-Helsinki
Telex: 12-1563

FRANCE

Hewlett-Packard France
Quartier de Courtaboeuf
Boîte Postale No. 6
F-91 Orsay
Tel: 1-920 88 01
Cable: HEWPACK Orsay
Telex: 60048

Hewlett-Packard France
4 Quai des Etruits
F-69 Lyon 5ème
Tel: 78-42 63 45
Cable: HEWPACK Lyon
Telex: 31617

Hewlett-Packard France
29 rue de la Gara
F-31 Biagnac
Tel: (61) 85 82 29
Telex: 51957

GERMANY

Hewlett-Packard Vertriebs-GmbH
Berliner Strasse 117
Postfach 560/40
D6 Nieder-Eschbach/Ffm 56
Tel: (0611) 50 10 64
Cable: HEWPACKSA Frankfurt
Telex: 41 32 49 FRA

Hewlett-Packard Vertriebs-GmbH
Wilmersdorfer Strasse 113/114
D-1000 Berlin W. 12
Tel: (0311) 3137046
Telex: 18 34 05

Hewlett-Packard Vertriebs-GmbH
Herrenbergerstrasse 110
D7090 Böblingen, Württemberg
Tel: (07031) 66 72 86
Cable: HEWPAK Böblingen
Telex: 72 65 739

Hewlett-Packard Vertriebs-GmbH
Vogelsanger Weg 38
D4 Düsseldorf
Tel: (0211) 63 80 31/35
Telex: 85/86 533

Hewlett-Packard Vertriebs-GmbH
Wendenstr. 23
D2 Hamburg 1
Tel: (0411) 24 05 51/52
Cable: HEWPACKSA Hamburg
Telex: 21 53 32

Hewlett-Packard Vertriebs-GmbH
Reginriedstrasse 13
D8 München 9
Tel: (0811) 69 59 71/75
Cable: HEWPACKSA München
Telex: 52 49 85

GREECE

Kostas Karayannis
18, Ermou Street
Athens 126
Tel: 230301,3,5
Cable: RAKAR Athens
Telex: 21 59 62 RKAR GR

IRELAND

Hewlett-Packard Ltd.
224 Bath Road
Slough, SL1 4 DS, Bucks
Tel: Slough 753-33341
Cable: HEWPIE Slough
Telex: 84413

ITALY

Hewlett-Packard Italiana S.p.A.
Via Amerigo Vespucci 2
I-20124 Milan
Tel: (2) 6251 (10 lines)
Cable: HEWPACKIT Milan
Telex: 32046

Hewlett-Packard Italiana S.p.A.
Palazzo Italia
Piazza Marconi 25
I-00144 Rome - Eur
Tel: 6-591 2544
Cable: HEWPACKIT Rome
Telex: 61514

NETHERLANDS

Hewlett-Packard Benelux, N.V.
Weerdestein 117
P.O. Box 7825
Amsterdam, Z 11
Tel: 020-42 77 77
Cable: PALOBEN Amsterdam
Telex: 13 216

NORWAY

Hewlett-Packard Norge A/S
Box 149
Nesveien 13
N-1344 Haslum
Tel: (02)-53 83 60
Cable: HEWPACK Oslo
Telex: 16621

PORTUGAL

Telectra
Empresa Tecnica de
Equipamentos
Eléctricos, S.a.r.l.
Rua Rodrigo da Fonseca 103
P.O. Box 2531
Lisbon 1
Tel: 68 60 72
Cable: TELECTRA Lisbon
Telex: 1598

SPAIN

Hewlett-Packard SA
Enrique Larreta 12
Madrid, 16
Tel: 215 35 43
Cable: TELEATAIO Madrid
Telex: 27249E

Ataio Ingenieros SA
Ganduxer 76
Barcelona 6
Tel: 211-44-66
Cable: TELEATAIO Barcelona

SWEDEN

Hewlett-Packard Sverige AB
Enighetsvägen 1-3
Fack
S-161 20 Bromma 20
Tel: (08) 98 12 50
Cable: MEASUREMENTS
Stockholm
Telex: 10721

Hewlett-Packard Sverige AB
Hagakergatan 9C
S-431 41 Mölndal
Tel: 031 - 27 68 00
Telex: 21 312 hpmindl

SWITZERLAND

Hewlett-Packard Schweiz AG
Zürcherstrasse 20
CH-8952 Schlieren Zurich
Tel: (051) 98 18 21/24
Cable: HPA8 CH
Telex: 53933

Hewlett-Packard Schweiz A.G.
Rue du Bois-du-Lan 7
1217 Meyrin 2 Geneva
Tel: (022) 41 54 00
Cable: HEWPACKSA Geneva
Telex: 27333 HPSA CH

TURKEY

Telekom Engineering Bureau
P.O. Box 376
Karakoy
Istanbul
Tel: 49 40 40
Cable: TELEMATON Istanbul

UNITED KINGDOM

Hewlett-Packard Ltd.
224 Bath Road
Slough, SL1 4 DS, Bucks
Tel: Slough (0753) 33341
Cable: HEWPIE Slough
Telex: 84413

Hewlett-Packard Ltd.
The Graftons
Stamford New Road
Atrincham, Cheshire
Tel: 061 928-8626
Telex: 668068

YUGOSLAVIA

Belram S.A.
83 avenue des Mimosas
Brussels 1150, Belgium
Tel: 34 33 32, 34 26 19
Cable: BELRAMEL Brussels
Telex: 21790

SOCIALIST COUNTRIES

PLEASE CONTACT:
Hewlett-Packard Ges.m.b.H
Innstrasse 23/2
Postfach
A1204 Vienna, Austria
Tel: (222) 3366 06/09
Cable: HEWPACK Vienna
Telex: 75923

ALL OTHER EUROPEAN COUNTRIES CONTACT:

Hewlett-Packard S.A.
Rue du Bois-du-Lan 7
1217 Meyrin 2 Geneva
Switzerland
Tel: (022) 41 54 00
Cable: HEWPACKSA Geneva
Telex: 2.24.86

AFRICA, ASIA, AUSTRALIA

ANGOLA

Telectra Empresa Técnica
de Equipamentos Eléctricos
SAR
Rua de Barbosa Rodrigues
42-1°
Box 6487
Luanda
Cable: TELECTRA Luanda

AUSTRALIA

Hewlett-Packard Australia
Pty. Ltd.
22-26 Weir Street
Glen Iris, 3146
Victoria
Tel: 20.1371 (6 lines)
Cable: HEWPARD Melbourne
Telex: 31024
Hewlett-Packard Australia
Pty. Ltd.
61 Alexander Street
Crows Nest 2065
New South Wales
Tel: 43.7866
Cable: HEWPARD Sydney
Telex: 21561

Hewlett-Packard Australia
Pty. Ltd.
97 Churchhill Road
Prospect 5082
South Australia
Tel: 65.2366
Cable: HEWPARD Adelaide

Hewlett-Packard Australia
Pty. Ltd.
2nd Floor, Suite 13
Casablanca Buildings
196 Adelaide Terrace
Perth, W.A. 6000
Tel: 21-3330
Cable: HEWPARD Perth

Hewlett-Packard Australia
Pty. Ltd.
10 Woolley Street
P.O. Box 191
Dickson A.C.T. 2602
Tel: 49-8194
Cable: HEWPARD Canberra ACT

Hewlett-Packard Australia
Pty. Ltd.
75 Simpsons Road
Bardon
Queensland, 4068
Tel: 36-5411

CEYLON

United Electricals Ltd.
P.O. Box 681
Yahala Building
Staples Street
Colombo 2
Tel: 5496
Cable: HOTPOINT Colombo

CYPRUS

Kytronics
19 Gregorios & Xenopoulos Road
P.O. Box 1152
Nicosia
Tel: 6282-75628
Cable: HE-I-NAMI

ETHIOPIA

African Salespower & Agency
Private Ltd., Co.
P. O. Box 718
58/59 Cunningham St.
Addis Ababa
Tel: 12285
Cable: ASACO Addisababa

HONG KONG

Schmidt & Co. (Hong Kong) Ltd.
P.O. Box 297
151, Prince's Building 15th Floor
10, Chater Road
Hong Kong
Tel: 240168, 232735
Cable: SCHMIDTCO Hong Kong

INDIA

Blue Star Ltd.
Kasturi Buildings
Jamshedji Tata Rd.
Bombay 20BR, India
Tel: 29 50 21
Telex: 2156
Cable: BLUEFROST

Blue Star Ltd.
Band Box House
Prabhadevi
Bombay 25DD, India
Tel: 45 73 01
Telex: 2156
Cable: BLUESTAR

Blue Star Ltd.
14/40 Civil Lines
Kanpur, India
Tel: 6 88 82
Cable: BLUESTAR

Blue Star Ltd.
7 Hare Street
P.O. Box 506
Calcutta 1, India
Tel: 23-0131
Telex: 655
Cable: BLUESTAR

Blue Star Ltd.
Blue Star House,
34 Ring Road
Lajpat Nagar
New Delhi 24, India
Tel: 62 32 76
Telex: 463
Cable: BLUESTAR

Blue Star Ltd.
17-C Ulsoor Road
Bangalore-8
Blue Star Ltd.
96 Park Lane
Secunderabad 3, India
Tel: 7 63 91
Cable: BLUEFROST

Blue Star Ltd.
23/24 Second Line Beach
Madras 1, India
Tel: 2 39 55
Telex: 379
Cable: BLUESTAR

Blue Star Ltd.
18 Kaiser Bungalow
Dindli Road
Jamshedpur, India
Tel: 38 04
Cable: BLUESTAR

INDONESIA
Bah Bohn Trading Coy. N.V.
Djaloh Merdeka 29
Bandung
Tel: 4915; 51560
Cable: ILMU
Telex: 08-809

IRAN

Telecom, Ltd.
P. O. Box 1812
240 Kh. Saba Shomali
Teheran
Tel: 43850, 48111
Cable: BASCOM Teheran

ISRAEL

Electronics & Engineering
Div. of Motorola Israel Ltd.
17 Aminadav Street
Tel-Aviv
Tel: 36941 (3 lines)
Cable: BASTEL Tel-Aviv
Telex: BasteL Tv 033-569

JAPAN

Yokogawa-Hewlett-Packard Ltd.
Ohashi Building
1-59-1 Yoyogi
Shibuya-ku, Tokyo
Tel: 03-370-2281/7
Telex: 232-2024YHP
Cable: YHPMARKET TOK 23-724

Yokogawa-Hewlett-Packard Ltd.
Nisei Ibaragi Bldg.
2-2-8 Kasuga
Ibaragi-Shi
Osaka
Tel: (0726) 23-1641
Telex: 385-5332 YHPOSAKA

Yokogawa-Hewlett-Packard Ltd.
Ito Building
No. 59, Kotori-cho
Nakamura-ku, Nagoya City
Tel: (052) 551-0215

Yokogawa-Hewlett-Packard Ltd.
Nitto Bldg.
2300 Shinohara-cho,
Kohoku-ku
Yokohama 222
Tel: (405) 432-1504/5

KENYA

Kenya Kinetics
P.O. Box 18311
Nairobi, Kenya
Tel: 57726
Cable: PROTON

KOREA

American Trading Co.,
Korea, Ltd.
Seoul P.O. Box 1103
7th & 8th floors, Daekyung Bldg.
107 Sejong Ro
Chongro-Ku, Seoul
Tel: 75-5841 (4 lines)
Cable: AMTRACO Seoul

LEBANON

Constantin E. Macridis
Clemenceau Street
P.O. Box 7213
Beirut
Tel: 220846
Cable: ELECTRONUCLEAR Beirut

MALAYSIA

MECOMB Malaysia Ltd.
2 Lorong 13/6A
Section 13
Petaling Jaya, Selangor
Cable: MECOMB Kuala Lumpur

MOZAMBIQUE

A. N. Goncalves, LDA.
4.1 Apt. 14 Av. D. Luis
P.O. Box 107
Lourenco Marques
Cable: NEGON
NEW ZEALAND
Hewlett-Packard (N.Z.) Ltd.
94-96 Dixon St.
P.O. Box 9443
Wellington, N.Z.
Tel: 56-559
Cable: HEWPACK Wellington
Hewlett-Packard (N.Z.) Ltd.
Box 51092
Pukuranga
Tel: 573-733
Cable: HEWPACK, Auckland

PAKISTAN (EAST)

Mushko & Company, Ltd.
1, Jinnah Avenue
Dacca 2
Tel: 280058
Cable: NEUDEAL Dacca

PAKISTAN (WEST)

Mushko & Company, Ltd.
Oosman Chambers
Abdullah Haroon Road
Karachi 3
Tel: 511027, 512927
Cable: COOPERATOR Karachi

PHILIPPINES

Electromex Inc.
Makati Commercial Center
2129 Pasong Tamo
Makati, Rizal D 708
P.O. Box 1028
Manila
Tel: 89-85-01; 88-91-71
Cable: ELEMEX Manila

SINGAPORE

Mechanical and Combustion
Engineering Company Ltd.
9, Jalan Kilang
Red Hill Industrial Estate
Singapore, 3
Tel: 642861-3; 632611
Cable: MECOMB Singapore

Hewlett-Packard Far East
Area Office
P.O. Box 87
Alexandra Post Office
Singapore 3
Tel: 633022
Cable: HEWPACK SINGAPORE

SOUTH AFRICA

Hewlett-Packard South Africa
(Pty.), Ltd.
P.O. Box 31716
Braamfontein Transvaal
Milnerton
30 De Beer Street
Johannesburg
Tel: 725-2080, 725-2030
Telex: 0226 JH
Cable: HEWPACK Johannesburg

Hewlett-Packard South Africa
(Pty.), Ltd.
Bree Street
Cape Town
Tel: 3-6019, 3-6545
Cable: HEWPACK Cape Town
Telex: 5-0006
Hewlett-Packard South Africa
(Pty.), Ltd.
308 Glenwood Centre
Corner Hunt & Moore Roads
P.O. Box 99
Overport, Natal
Tel: 347536

TAIWAN

Hewlett-Packard Taiwan
39 Chung Shiao West Road
Sec. 1
Overseas Insurance
Corp. Bldg. 7th Floor
Taipei
Tel: 579-605, 579-610, 579-613
Telex: TP824 HEWPACK
Cable: HEWPACK Taipei

THAILAND

The International
Engineering Co., Ltd.
P. O. Box 39
614 Sukhumvit Road
Bangkok
Tel: 910722 (7 lines)
Cable: GYSOM
TLX INTENCO BK-226 Bangkok

UGANDA

Uganda Tele-Electric Co., Ltd.
P.O. Box 4449
Kampala
Tel: 57279
Cable: COMCO Kampala

VIETNAM

Penninsular Trading Inc.
P.O. Box H-3
216 Hien-Vuong
Saigon
Tel: 20805, 93398
Cable: PENTRA, SAIGON 242

ZAMBIA

R. J. Tilbury (Zambia) Ltd.
P.O. Box 2792
Lusaka
Zambia, Central Africa
Tel: 73793
Cable: ARJAYTEE, Lusaka

MEDITERRANEAN AND MIDDLE EAST COUNTRIES NOT SHOWN PLEASE CONTACT:

Hewlett-Packard Correspondence
Office
Piazza Marconi 25
I-00144 Rome-Eur, Italy
Tel: (6) 59 40 29
Cable: HEWPACKIT Rome
Telex: 61514

OTHER AREAS NOT LISTED, CONTACT:

Hewlett-Packard
INTERCONTINENTAL
3200 Hillview Ave.
Palo Alto, California 94304
Tel: (415) 326-7000
(Feb. 71 493-1501)
TWX: 910-373-1267
Cable: HEWPACK Palo Alto
Telex: 034-8461

TABLE 6-3. CODE LIST OF MANUFACTURERS (CONT'D)

Code No.	Manufacturer	Address	Code No.	Manufacturer	Address	Code No.	Manufacturer	Address	Code No.	Manufacturer	Address
82209	Maguire Industries, Inc.	Greenwich, Conn.	87664	Van Waters & Rogers Inc.	Seattle, Wash.	95263	Leecraft Mig. Co., Inc.	New York, N.Y.	THE FOLLOWING H-P VENDORS HAVE NO NUMBER ASSIGNED IN THE LATEST SUPPLEMENT TO THE FEDERAL SUPPLY CODE FOR MANUFACTURERS HANDBOOK.		
82219	Sylvania Electric Prod. Inc.	Emporium, Pa.	88180	Cutler-Hammer, Inc.	Lincoln, Ill.	95264	Lorco Electronics, Inc.	Burbank, Calif.	C0090	JFD Electronics Corp.	Van Nuys, Calif.
82376	Astron Co.	East Newark, N.J.	88220	Gould-National Batteries, Inc.	St. Paul, Minn.	95265	National Coil Co.	Sheridan, Wyo.	G0090	Tronex Company	Mountain View, Calif.
82389	Switchcraft, Inc.	Chicago, Ill.	88698	General Mills, Inc.	Buffalo, N.Y.	95275	Vilramon, Inc.	Bridgeport, Conn.	I0000	Western Devices, Inc.	Inglewood, Calif.
82647	Metals and Conkols, Inc., Div. of Texas Instruments, Inc., Spencer Prods.	Atleboro, Mass.	89473	General Electric Distributing Corp.	Schenectady, N.Y.	95348	Gordas Corp.	Bloomfield, N.J.	J0000	Winchester Electronics, Inc.	Santa Monica, Calif.
82866	Research Products Corp.	Madison, Wis.	89536	Carter Paris Div. of Economy Baler Co.	Chicago, Ill.	95354	Methode Mig. Co.	Chicago, Ill.	0000F	Malco Tool and Die	Los Angeles, Calif.
82877	Rotron Manufacturing Co., Inc.	Woodstock, N.Y.	90179	U S Rubber Co. Mechanical Goods Div.	Passaic, N.J.	95367	Whechser Co.	Chicago, Ill.	0000H	Western Coil Div. of Automatic Ind., Inc.	Redwood City, Calif.
82893	Vector Electronic Co.	Glendale, Calif.	90970	Bearing Engineering Co.	San Francisco, Calif.	95387	Huggins Laboratories	Sunnyvale, Calif.	0000N	Nahn-Bros. Spring Co.	San Leandro, Calif.
83053	Western Washer Mfr. Co.	Los Angeles, Calif.	91260	Conner Spring Mig. Co.	San Francisco, Calif.	95085	Hi-Q Division of Aerovox	Olean, N.Y.	0000O	U.S.A. Common	Any supplier of U.S.
83058	Carr Fastener Co.	Cambridge, Mass.	91745	Miller Dial & Nameplate Co.	El Monte, Calif.	96256	Thordarson-Meissner Div. of Maguire Industries, Inc.	Mt. Carmel, Ill.	0000P	Ty-Car Mig. Co., Inc.	Holliston, Mass.
83086	New Hampshire Ball Bearing, Inc.	Peterborough, N.H.	91418	Radio Materials Co.	Chicago, Ill.	96256	Thordarson-Meissner Div. of Maguire Industries, Inc.	Mt. Carmel, Ill.	0000T	Texas Instruments, Inc.	Versailles, Ky.
83125	Pyramid Electric Co.	Darlington, S.C.	91506	Augal Brothers' Inc.	Atleboro, Mass.	96296	Solar Manufacturing Co.	Los Angeles, Calif.	0000U	Tower Mig. Corp.	Providence, R.I.
83148	Electro Cords Co.	Los Angeles, Calif.	91637	Dale Electronics Inc.	Columbus, Nebr.	96330	Carlton Screw Co.	Chicago, Ill.	0000V	Wehster Electronics Co. Inc.	New York, N.Y.
83186	Victory Engineering Corp.	Union, N.J.	91662	Elice Corp.	Philadelphia, Pa.	96341	Microwave Associates, Inc.	Burlington, Mass.	0000X	Spruce Pine Mica Co.	Spruce Pine, N.C.
83298	Bendix Corp., Red Bank Div.	Red Bank, N.J.	91737	Grewar Mig. Co., Inc.	Waterford, Mass.	96501	Excel Transformer Co.	Oakland, Calif.	0000Y	Midland Mig. Co. Inc.	Kansas City, Kans.
83315	Hubbell Corp.	Mundelein, Ill.	91827	K F Development Co.	Redwood City, Calif.	97464	Industrial Retaining Ring Co.	Irvine, Calif.	0000Z	Willow Leather Products Corp.	Newark, N.J.
83330	Smith, Herman H., Inc.	Brooklyn, N.Y.	91929	Minneapolis-Honeywell Regulator Co.	Minneapolis, Minn.	97539	Automatic and Precision Mig. Co.	Yonkers, N.Y.	0000A	British Radio Electronics Ltd.	Washington, D.C.
83385	Central Screw Co.	Chicago, Ill.	92196	Microswitch Div.	Freeport, Ill.	97539	Automatic and Precision Mig. Co.	Yonkers, N.Y.	0000B	ETA	England
83501	Gavitt Wire and Cable Co., Div. of Amerace Corp.	Brookfield, Mass.	92367	Universal Metal Prod. Inc.	Bassett, Paente, Calif.	97979	Reon Resistor Corp.	Yonkers, N.Y.	0000C	Indiana General Corp., Elect. Div.	Indiana
83554	Burroughs Corp., Electronic Tube Div.	Plainfield, N.J.	92607	Elgeet Optical Co., Inc.	Rochester, N.Y.	98141	Asel Brothers Inc.	Jamaica, N.Y.	0000D	Curtis Instrument Inc.	Mt. Kisco, N.Y.
83740	Eveready Battery	New York, N.Y.	92607	Tinsolite Insulated Wire Co.	Tarrytown, N.Y.	98159	Rubber Teck, Inc.	Gardena, Calif.	0000E	Precision Instrument Components Co.	Van Nuys, Calif.
83777	Model Eng. and Mig., Inc.	Huntington, Ind.	93332	Sylvania Electric Prod. Inc., Semiconductor Div.	Woburn, Mass.	98278	Francis L. Mosley	Pasadena, Calif.	0000F	Computer Diode Corp.	Lodi, N.J.
83821	Loyd Scroggs Co.	Fenton, Mo.	93369	Robbins and Myers, Inc.	New York, N.Y.	98405	Carad Corp.	Redwood City, Calif.	0000G	A. Williams Manufacturing Co.	San Jose, Calif.
84171	Arco Electronics, Inc.	New York, N.Y.	93410	Stevens Mig. Co., Inc.	Mansfield, Ohio	98405	Carad Corp.	Redwood City, Calif.	0000H	Goshen Die Cutting Service	Coshen, Ind.
84396	A.J. Gieseler Co., Inc.	San Francisco, Calif.	93583	Insulma-Van Vorssa Ind., Inc.	Manassas, Va.	98821	North Hills Electric Co.	Mineola, N.Y.	0000I	Rubbercraft Corp.	Torrance, Calif.
84411	Good All Electric Mig. Co.	Ogallala, Neb.	94144	Electronic Division	Manchester, N.H.	98925	Clevite Transistor Prod. Div. of Clevite Corp.	Waltham, Mass.	0000J	Birtcher Corporation, Industrial Division	Monterey Park Calif.
84970	Sarkis Tarzian, Inc.	Bloomington, Ind.	94144	Raytheon Mig. Co., Industrial Components Div., Receiving Tube Operation	Quincy, Mass.	98978	International Electronic Research Corp.	Burbank, Calif.	0000K	Amatlon	New Rochelle, N.Y.
85454	Beenton Molding Company	Beenton, N.J.	94145	Raytheon Mig. Co., Semiconductor Div., California Street Plant	Newton, Mass.	99109	Columbia Technical Corp.	New York, N.Y.	0000L	Avery Label	Monrovia, Calif.
85471	A.B. Boyd Co.	San Francisco, Calif.	94148	Scientific Radio Products, Inc.	Loveland, Colo.	99313	Varian Associates	Palo Alto, Calif.	0000M	Rubber Eng. & Development	Hayward, Calif.
85474	R.M. Bracamonte & Co.	San Francisco, Calif.	94154	Tung-Sol Electric, Inc.	Newark, N.J.	99515	Marshall Industries, Electron Prodcus Division	Pasadena, Calif.	0000N	A "H" D Manufacturing Co.	San Jose 27, Calif.
85660	Koiled Kords, Inc.	New Haven, Conn.	94197	Curtiss-Wright Corp., Electronics Div.	East Paterson, N.J.	99707	Control Switch Division, Controls Co. of America	El Segundo, Calif.	0000P	Atom Electronics	Sun Valley, Calif.
85911	Seamless Rubber Co.	Chicago, Ill.	94310	Tru Ohm Prod. Div. of Model Engineering and Mig. Co.	Chicago, Ill.	99800	Delevan Electronics Corp.	East Aurora, N.Y.	0000Q	Cosiltron	Oakland, Calif.
86157	Clifton Precision Products	Clifton Heights, Pa.	94682	Worcester Pressed Aluminum Corp.	Worcester, Mass.	99848	Wilco Corporation	Indianapolis, Ind.	0000R	Radio Industries	Des Plaines, Ill.
86579	Precision Rubber Products Corp.	Dayton, Ohio	95023	Philbrick Researchers, Inc.	Boston, Mass.	99934	Rebraand, Inc.	Boston, Mass.	0000S	Control of Elgin Watch Co.	Burbank, Calif.
86584	Radio Corp. of America, RCA Electron Tube Div.	Harrison, N.J.	95236	Allies Products Corp.	Miami, Fla.	99942	Hoffman Semiconductor Div. of Hoffman Electronics Corp.	Evanston, Ill.	0000W	California Eastern Lab.	Burlingame, Calif.
87216	Phlita Corporation (Lansdale Division)	Lansdale, Pa.	95238	Contraental Connector Corp.	Woodside, N.Y.	99957	Technology Instrument Corp of Calif.	Newbury Park, Calif.	0000X	Melroe Electronics, Inc.	Chicago 31, Ill.
87473	Western Fibrous Glass Products Co.	San Francisco, Calif.							0000Y	S.K. Smith Co.	Los Angeles 45, Calif.

00015-34
Revised: Nov 14, 1963

From: F.S.C. Handbook Supplements
H4-1 Dated March 1963
H4-2 Dated March 1962

